



FAA-H-8083-30A

Aviation Maintenance Technician Handbook- General



U.S. Department
of Transportation

Federal Aviation
Administration

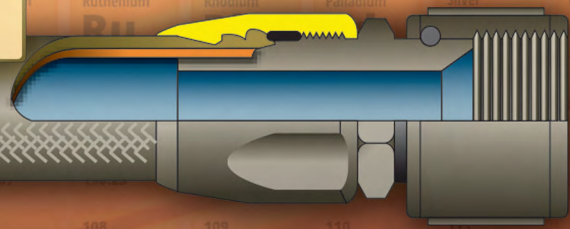
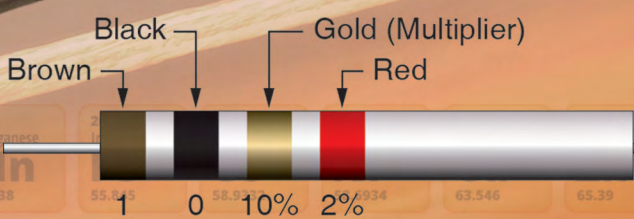
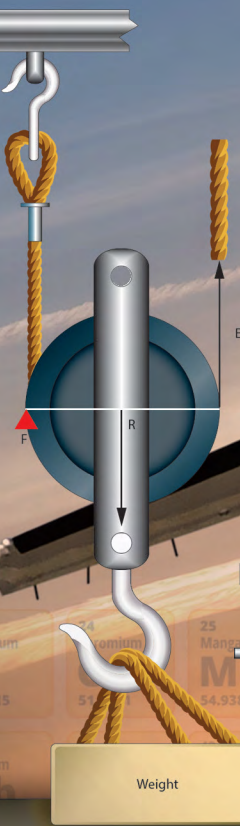
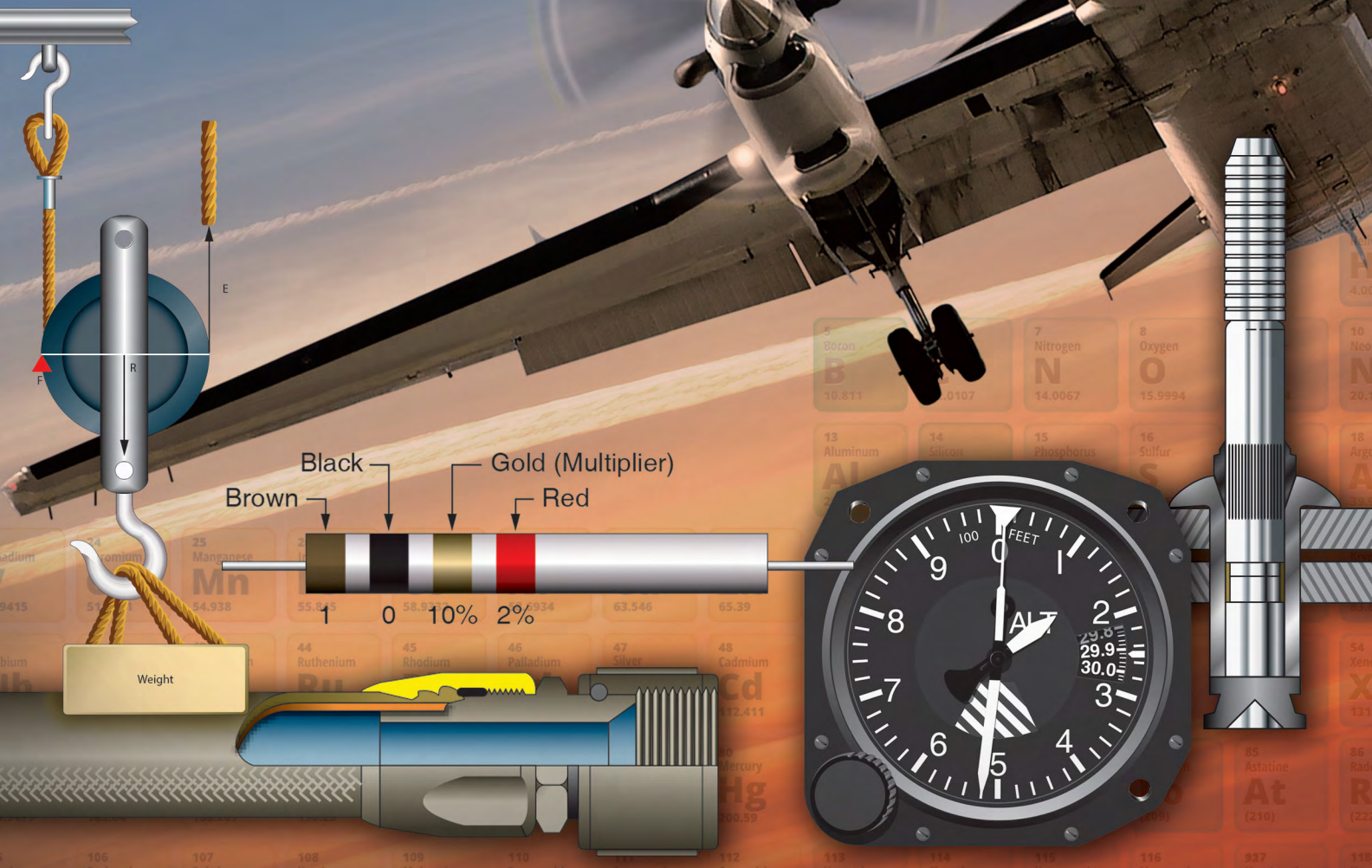

Aviation Maintenance Technician Handbook—General

2018

U.S. Department of Transportation
FEDERAL AVIATION ADMINISTRATION
Flight Standards Service

Aviation Maintenance Technician Handbook – General
2018

FAA-H-8083-30A

Aviation Supplies & Academics, Inc.
7005 132nd Place SE
Newcastle, Washington 98059-3153
www.asa2fly.com

© 2018 Aviation Supplies & Academics, Inc.

This electronic publication is comprised of the same content as the Federal Aviation Administration's official release of this same title. ASA does not claim copyright on any material published herein that was taken from United States government sources. Bookmarks and hyperlinks have been incorporated throughout to facilitate ease of use for this electronic version. All rights reserved. No part of this electronic file may be reproduced, transmitted, shared, distributed or resold without written permission from the publisher.

ASA-8083-30A-PD
ISBN 978-1-61954-695-0

Preface

The *Aviation Maintenance Technician Handbook—General (FAA-H-8083-30A)* was developed as one of a series of three handbooks for persons preparing for mechanic certification with airframe or powerplant ratings, or both. It is intended that this handbook will provide basic information on principles, fundamentals, and technical procedures in the subject matter areas common to both the airframe and powerplant ratings. Emphasis in this volume is on theory and methods of application.

The handbook is designed to aid students enrolled in a formal course of instruction preparing for FAA certification as a maintenance technician as well as for current technicians who wish to improve their knowledge. This volume contains information on mathematics, aircraft drawings, weight and balance, aircraft materials, processes and tools, physics, electricity, inspection, ground operations, and FAA regulations governing the certification and work of maintenance technicians. New to this volume is a section addressing how successful aviation maintenance technicians incorporate knowledge and awareness of ethics, professionalism and human factors in the field.

Because there are so many different types of airframes and powerplants in use today, it is reasonable to expect that differences exist in the components and systems of each. To avoid undue repetition, the practice of using representative systems and units is implemented throughout the handbook. Subject matter treatment is from a generalized point of view, and should be supplemented by reference to manufacturers' manuals or other textbooks if more detail is desired. This handbook is not intended to replace, substitute for, or supersede official regulations or the manufacturers' instructions.

The companion handbooks to *Aviation Maintenance Technician Handbook—General (FAA-H-8083-30A)* are the *Aviation Maintenance Technician Handbook—Airframe (FAA-H-8083-31 (as amended))*, and the *Aviation Maintenance Technician Handbook—Powerplant (FAA-H-8083-32 (as amended))*.

This handbook is available for download, in pdf format, from www.faa.gov. Please visit this website for the latest version of all FAA handbooks.

This handbook is published by the U.S. Department of Transportation, Federal Aviation Administration, Airmen Testing Standards Branch, AFS-630, P.O. Box 25082, Oklahoma City, OK 73125.

Comments regarding this publication should be emailed to afs630comments@faa.gov.

John S. Duncan
Director, Flight Standards Service

Table of Contents

Preface	iii	Extinguishing Engine Fires	1-15
Acknowledgments	v	Turboprop Engines	1-15
Table of Contents	VII	Turboprop Starting Procedures	1-15
Chapter 1		Turbofan Engines	1-16
Safety, Ground Operations, and Servicing	1-1	Starting a Turbofan Engine	1-17
Shop Safety	1-2	Auxiliary Power Units (APUs)	1-17
Electrical Safety	1-2	Unsatisfactory Turbine Engine Starts.....	1-17
Physiological Safety	1-2	Hot Start.....	1-17
Fire Safety.....	1-2	False or Hung Start	1-17
Safety Around Compressed Gases	1-2	Engine Fails to Start.....	1-19
Safety Around Hazardous Materials	1-3	Towing of Aircraft.....	1-19
Safety Around Machine Tools	1-3	Taxiing Aircraft.....	1-20
Flight Line Safety	1-4	Taxi Signals	1-21
Hearing Protection.....	1-4	Servicing Aircraft.....	1-22
Foreign Object Damage (FOD).....	1-5	Servicing Aircraft Air/Nitrogen Oil and Fluids	1-22
Safety Around Airplanes.....	1-5	Ground Support Equipment	1-24
Safety Around Helicopters	1-5	Electric Ground Power Units.....	1-24
Fire Safety	1-5	Hydraulic Ground Power Units	1-25
Fire Protection.....	1-5	Ground Support Air Units	1-25
Requirements for Fire to Occur.....	1-5	Ground Air Heating and Air Conditioning.....	1-25
Classification of Fires.....	1-6	Oxygen Servicing Equipment	1-25
Types and Operation of Shop and Flight Line Fire		Oxygen Hazards	1-26
Extinguishers.....	1-6	Fuel Servicing of Aircraft	1-26
Inspection of Fire Extinguishers.....	1-8	Types of Fuel and Identification	1-26
Identifying Fire Extinguishers.....	1-8	Contamination Control	1-26
Using Fire Extinguishers	1-9	Fueling Hazards.....	1-27
Tie-Down Procedures	1-9	Fueling Procedures	1-27
Preparation of Aircraft.....	1-9	Defueling	1-29
Tie-Down Procedures for Land Planes	1-10		
Securing Light Aircraft.....	1-10	Chapter 2	
Securing Heavy Aircraft.....	1-11	Regulations, Maintenance Forms,	
Tie-Down Procedures for Seaplanes	1-11	Records, and Publications	2-1
Tie-Down Procedures for Ski Planes	1-11	Overview — Title 14 of the Code of Federal	
Tie-Down Procedures for Helicopters.....	1-11	Regulations (14 CFR).....	2-1
Procedures for Securing Weight-Shift-Control	1-12	Title 14 CFR Part 3—General Requirements.....	2-4
Procedures for Securing Powered Parachutes	1-12	Maintenance-Related Regulations.....	2-5
Ground Movement of Aircraft.....	1-13	14 CFR Part 1—Definitions and Abbreviations.....	2-5
Engine Starting and Operation	1-13	14 CFR Part 21—Certification Procedures for	
Reciprocating Engines.....	1-13	Products and Parts.....	2-5
Hand Cranking Engines.....	1-14		

14 CFR Part 23—Airworthiness Standards: Normal, Utility, Acrobatic, and Commuter Category Airplanes	2-8	Included in Annual and 100-Hour Inspections	2-21
14 CFR Part 25—Airworthiness Standards: Transport Category Airplanes.....	2-8	Appendix E—Altimeter System Test and Inspection.....	2-21
14 CFR Part 27—Airworthiness Standards: Normal Category Rotorcraft	2-8	Appendix F—ATC Transponder Tests and Inspections	2-21
14 CFR Part 29—Airworthiness Standards: Transport Category Rotorcraft.....	2-8	14 CFR Part 91—General Operating and Flight Rules	2-21
14 CFR Part 33—Airworthiness Standards: Aircraft Engines.....	2-8	Subpart A—General	2-21
14 CFR Part 35—Airworthiness Standards: Propellers	2-8	Subpart E—Maintenance, Preventive Maintenance, and Alterations	2-22
14 CFR Part 39—Airworthiness Directives	2-10	Civil Air Regulations (CAR)	2-24
14 CFR Part 43—Maintenance, Preventive Maintenance, Rebuilding, and Alteration	2-10	CAR 3—Airplane Airworthiness—Normal, Utility, Aerobatic, and Restricted Purpose Categories.....	2-24
14 CFR Part 45—Identification and Registration Marking	2-10	CAR 4a—Airplane Airworthiness	2-26
14 CFR Part 47—Aircraft Registration	2-10	Suspected Unapproved Parts (SUP).....	2-26
14 CFR Part 65—Certification: Airmen Other Than Flight Crewmembers	2-10	Other FAA Documents	2-26
14 CFR Part 91—General Operating and Flight Rules.....	2-11	Advisory Circulars (AC)	2-26
14 CFR Part 119—Certification: Air Carriers and Commercial Operators	2-11	The AC Numbering System.....	2-26
14 CFR Part 121—Operating Requirements: Domestic, Flag, and Supplemental Operations.....	2-12	Types of Airworthiness Directives (AD).....	2-27
14 CFR Part 125—Certification and Operations: Airplanes Having a Seating Capacity of 20 or More Passengers or a Maximum Payload Capacity of 6,000 Pounds or More; and Rules Governing Persons on Board Such Aircraft	2-13	AD Content	2-27
14 CFR Part 135—Operating Requirements: Commuter and On-Demand Operations and Rules Governing Persons on Board Such Aircraft.....	2-13	AD Number	2-27
14 CFR Part 145—Repair Stations.....	2-14	Applicability and Compliance	2-27
14 CFR Part 147—Aviation Maintenance Technician Schools	2-14	Alternative Method of Compliance	2-30
14 CFR Part 183—Representatives of the Administrator.....	2-14	Special Airworthiness Information Bulletin (SAIB)	2-30
Explanation of Primary Regulations (Parts 43 and 91)	2-15	Aircraft Specifications.....	2-30
14 CFR Part 43—Maintenance, Preventative Maintenance Rebuilding, and Alteration.....	2-15	Cessna; 182T; Locked Rudder Trim Wheel; A4A 2721.....	2-30
Appendix A—Major Alterations, Major Repairs, and Preventive Maintenance.....	2-20	Supplemental Type Certificates (STC)	2-30
Appendix B—Recording of Major Repairs and Major Alterations	2-21	Type Certificate Data Sheets (TCDS).....	2-33
Appendix C—(Reserved)	2-21	FAA Handbooks and Manuals.....	2-33
Appendix D—Scope and Detail of Items To Be		Non-FAA Documents	2-33
		Air Transport Association A4A iSPec 2200	2-33
		Manufacturers’ Published Data.....	2-33
		Airworthiness Limitations	2-37
		Service Bulletins (SB).....	2-38
		Structural Repair Manual (SRM)	2-38
		Forms	2-39
		Airworthiness Certificates	2-39
		Aircraft Registration.....	2-39
		Radio Station License.....	2-39
		FAA Form 337—Major Repair and Alteration.....	2-40
		Records	2-41
		Making Maintenance Record Entries	2-41
		Electronic Records	2-44
		Light Sport Aircraft (LSA)	2-45
		Maintenance	2-45
		Aircraft Maintenance Manual (AMM).....	2-46
		Line Maintenance, Repairs, and Alterations	2-46
		Major Repairs and Alterations	2-46

Chapter 3

Mathematics in Aviation Maintenance.....3-1

Introduction.....	3-1
Whole Numbers	3-2
Addition of Whole Numbers.....	3-2
Subtraction of Whole Numbers.....	3-2
Division of Whole Numbers.....	3-2
Fractions.....	3-2
Finding the Least Common Denominator.....	3-3
Addition of Fractions	3-3
Subtraction of Fractions	3-3
Multiplication of Fractions.....	3-3
Division of Fractions.....	3-4
Reducing Fractions.....	3-4
Mixed Numbers	3-4
Addition of Mixed Numbers	3-4
Subtraction of Mixed Numbers	3-4
The Decimal Number System.....	3-5
Origin and Definition	3-5
Addition of Decimal Numbers	3-5
Subtraction of Decimal Numbers.....	3-6
Multiplication of Decimal Numbers.....	3-6
Division of Decimal Numbers.....	3-6
Rounding Off Decimal Numbers	3-7
Converting Decimal Numbers to Fractions.....	3-7
Converting Fractions to Decimals.....	3-8
Decimal Equivalent Chart	3-8
Ratio.....	3-8
Aviation Applications.....	3-8
Proportion	3-10
Extremes and Means	3-10
Solving Proportions.....	3-10
Percentage.....	3-10
Expressing a Decimal Number as a Percentage	3-10
Expressing a Percentage as a Decimal Number	3-11
Expressing a Fraction as a Percentage	3-11
Finding a Percentage of a Given Number	3-11
Finding What Percentage One Number is of Another.....	3-11
Finding a Number When a Percentage of it is Known	3-11
Positive and Negative Numbers.....	3-12
(Signed Numbers).....	3-12
Addition of Positive and Negative Numbers.....	3-12
Subtraction of Positive and Negative Numbers	3-12
Multiplication of Positive and Negative Numbers.....	3-12
Powers.....	3-12
Special Powers	3-12
Squared	3-12
Cubed.....	3-12
Power of Zero	3-12

Law of Exponents.....	3-13
Powers of Ten.....	3-13
Roots.....	3-13
Square Roots	3-13
Cube Roots	3-13
Fractional Powers.....	3-16
Functions of Numbers Chart.....	3-16
Scientific Notation	3-16
Converting Numbers from Standard Notation to Scientific Notation.....	3-16
Converting Numbers from Scientific Notation to Standard Notation.....	3-16
Addition, Subtraction, Multiplication, and Division of Scientific Numbers.....	3-17
Algebra.....	3-17
Equations.....	3-17
Algebraic Rules	3-17
Solving for a Variable	3-17
Use of Parentheses.....	3-18
Order of Operation	3-18
Order of Operation for Algebraic Equations.....	3-18
Computing Area of Two-Dimensional Solids	3-18
Rectangle.....	3-19
Square.....	3-19
Triangle	3-19
Parallelogram.....	3-20
Trapezoid.....	3-20
Circle	3-21
Ellipse.....	3-21
Units of Area	3-22
Computing Volume of Three-Dimensional Solids	3-22
Rectangular Solid	3-23
Cube	3-23
Cylinder.....	3-24
Sphere.....	3-24
Cone	3-25
Units of Volume	3-25
Computing Surface Area of Three-Dimensional Solids.....	3-25
Rectangular Solid	3-25
Cube	3-25
Cylinder.....	3-25
Sphere.....	3-25
Cone	3-25
Trigonometric Functions.....	3-26
Right Triangle, Sides, and Angles.....	3-26
Sine, Cosine, and Tangent.....	3-26
Calculator Method:	3-26
Trigonometry Table Method:	3-26
Pythagorean Theorem.....	3-26

Measurement Systems	3-27	Extension Lines	4-19
Conventional (U.S. or English) System	3-27	Sectioning Lines	4-19
Metric System	3-27	Phantom Lines	4-19
Measurement Systems and Conversions	3-28	Break Lines.....	4-19
The Binary Number System.....	3-28	Leader Lines	4-19
Place Values	3-28	Hidden Lines	4-19
Converting Binary Numbers to Decimal		Outline or Visible Lines	4-19
Numbers	3-28	Stitch Lines.....	4-19
Converting Decimal Numbers to Binary		Cutting Plane and Viewing Plane Lines.....	4-19
Numbers	3-28	Drawing Symbols.....	4-20
Chapter 4		Material Symbols	4-20
Aircraft Drawings.....	4-1	Shape Symbols	4-21
Computer Graphics	4-2	Electrical Symbols.....	4-21
Purpose and Function of Aircraft Drawings	4-2	Reading and Interpreting Drawings	4-21
Care and Use of Drawings	4-2	Drawing Sketches	4-23
Types of Drawings	4-3	Sketching Techniques.....	4-23
Detail Drawing	4-3	Basic Shapes.....	4-23
Assembly Drawing	4-3	Repair Sketches	4-23
Installation Drawing.....	4-3	Care of Drafting Instruments	4-23
Sectional View Drawings.....	4-3	Graphs and Charts.....	4-25
Full Section.....	4-3	Reading and Interpreting Graphs and Charts	4-25
Half Section	4-3	Nomograms	4-25
Revolved Section	4-3	Microfilm and Microfiche.....	4-25
Removed Section	4-3	Digital Images.....	4-26
Title Blocks.....	4-3	Chapter 5	
Drawing or Print Numbers	4-7	Physics for Aviation	5-1
Reference and Dash Numbers	4-8	Matter.....	5-2
Universal Numbering System	4-8	Characteristics of Matter	5-2
Drawing Standards.....	4-8	Mass and Weight	5-2
Bill of Material.....	4-8	Attraction	5-2
Other Drawing Data.....	4-9	Porosity	5-2
Revision Block	4-9	Impenetrability.....	5-2
Notes.....	4-9	Density	5-2
Zone Numbers	4-9	Specific Gravity	5-2
Station Numbers and Location Identification on		Energy	5-4
Aircraft	4-9	Potential Energy	5-4
Allowances and Tolerances.....	4-9	Kinetic Energy.....	5-4
Finish Marks.....	4-9	Force, Work, Power, and Torque.....	5-4
Scale	4-11	Force.....	5-4
Application	4-11	Work.....	5-5
Methods of Illustration.....	4-11	Friction and Work	5-5
Applied Geometry	4-11	Static Friction.....	5-6
Orthographic Projection Drawings	4-11	Sliding Friction	5-6
Pictorial Drawings	4-11	Rolling Friction.....	5-6
Diagrams.....	4-15	Power.....	5-7
Flowcharts.....	4-17	Torque	5-7
Lines and Their Meanings	4-17	Simple Machines.....	5-8
Centerlines.....	4-18	Mechanical Advantage of Machines	5-8
Dimension Lines	4-18		

The Lever	5-9	Sound	5-31
First Class Lever	5-9	Wave Motion	5-31
Second Class Lever	5-9	Speed of Sound	5-32
Third Class Lever	5-10	Mach Number	5-32
The Pulley	5-10	Frequency of Sound	5-32
Single Fixed Pulley	5-10	Loudness	5-32
Single Movable Pulley	5-10	Measurement of Sound Intensity	5-33
Block and Tackle	5-11	Doppler Effect	5-33
The Gear	5-11	Resonance	5-33
Inclined Plane	5-13	The Atmosphere	5-33
Stress	5-13	Composition of the Atmosphere	5-34
Tension	5-14	Atmospheric Pressure	5-34
Compression	5-14	Atmospheric Density	5-35
Torsion	5-14	Water Content of the Atmosphere	5-35
Bending	5-15	Absolute Humidity	5-36
Shear	5-15	Relative Humidity	5-36
Strain	5-15	Dew Point	5-36
Motion	5-15	Vapor Pressure	5-37
Uniform Motion	5-16	Standard Atmosphere	5-37
Speed and Velocity	5-16	Aircraft Theory of Flight	5-37
Acceleration	5-16	Four Forces of Flight	5-37
Newton's Law of Motion	5-17	Bernoulli's Principle and Subsonic Flow	5-37
First Law	5-17	Lift and Newton's Third Law	5-38
Second Law	5-17	Airfoils	5-39
Third Law	5-18	Camber	5-39
Circular Motion	5-18	Chord Line	5-39
Heat	5-19	Relative Wind	5-39
Heat Energy Units	5-19	Angle of Attack	5-39
Heat Energy and Thermal Efficiency	5-19	Boundary Layer Airflow	5-40
Heat Transfer	5-20	Boundary Layer Control	5-40
Conduction	5-20	Wingtip Vortices	5-40
Convection	5-21	Axes of an Aircraft	5-41
Radiation	5-21	Aircraft Stability	5-41
Specific Heat	5-22	Static Stability	5-41
Temperature	5-22	Dynamic Stability	5-42
Thermal Expansion/Contraction	5-23	Longitudinal Stability	5-42
Pressure	5-23	Lateral Stability	5-43
Gauge Pressure	5-24	Directional Stability	5-43
Absolute Pressure	5-24	Dutch Roll	5-43
Differential Pressure	5-24	Flight Control Surfaces	5-43
Gas Laws	5-25	Flight Controls and the Lateral Axis	5-43
Boyle's Law	5-25	Flight Controls and the Longitudinal Axis	5-44
Charles' Law	5-26	Flight Controls and the Vertical Axis	5-44
General Gas Law	5-26	Tabs	5-45
Dalton's Law	5-26	Supplemental Lift-Modifying Devices	5-46
Fluid Mechanics	5-26	High-Speed Aerodynamics	5-47
Buoyancy	5-26	Compressibility Effects	5-47
Fluid Pressure	5-28	The Speed of Sound	5-48
Pascal's Law	5-28	Subsonic, Transonic, and Supersonic Flight	5-48
Bernoulli's Principle	5-30		

Shock Waves	5-48
High-Speed Airfoils	5-49
Aerodynamic Heating	5-50
Helicopter Aerodynamics	5-51
Helicopter Structures and Airfoils	5-51
Helicopter Axes of Flight	5-54
Helicopters in Flight	5-56
Weight-Shift Control, Flexible Wing Aircraft Aerodynamics	5-58
Powered Parachute Aerodynamics	5-60

Chapter 6

Aircraft Weight and Balance.....	6-1
Introduction	6-1
Requirements for Aircraft Weighing	6-2
Weight and Balance Terminology	6-2
Datum	6-2
Arm.....	6-3
Moment	6-3
Center of Gravity (CG).....	6-4
Maximum Weight.....	6-4
Empty Weight.....	6-4
Empty Weight Center of Gravity (EWCG).....	6-5
Useful Load	6-5
Minimum Fuel.....	6-5
Tare Weight.....	6-6
Procedures for Weighing an Aircraft.....	6-6
General Concepts	6-6
Weight and Balance Data.....	6-7
Manufacturer-Furnished Information.....	6-8
Weight and Balance Equipment.....	6-8
Scales.....	6-8
Spirit Level	6-12
Plumb Bob	6-13
Hydrometer	6-13
Preparing an Aircraft for Weighing.....	6-13
Fuel System	6-14
Oil System	6-14
Miscellaneous Fluids	6-14
Flight Controls	6-14
Other Considerations	6-14
Weighing Points.....	6-15
Jacking the Aircraft	6-15
Leveling the Aircraft	6-15
Safety Considerations.....	6-16
CG Range	6-16
Empty Weight Center of Gravity (EWCG) Range	6-16
Operating CG Range.....	6-16

Standard Weights Used for Aircraft Weight and Balance.....	6-17
Example Weighing of an Airplane.....	6-17
EWCG Formulas	6-18
Datum Forward of the Airplane–Nosewheel Landing Gear	6-19
Datum Aft of the Main Wheels–Nosewheel Landing Gear	6-19
Location of Datum.....	6-19
Datum Forward of the Main Wheels–Tail Wheel Landing Gear	6-20
Loading an Aircraft for Flight.....	6-20
Example Loading of an Airplane.....	6-20
Adverse-Loaded CG Checks	6-21
Example Forward and Aft Adverse-Loaded CG Checks.....	6-22
Equipment Change and Aircraft Alteration	6-23
Example Calculation After an Equipment Change	6-23
Use of Ballast	6-23
Temporary Ballast	6-23
Permanent Ballast	6-25
Loading Graphs and CG Envelopes.....	6-25
Helicopter Weight and Balance	6-27
General Concepts	6-27
Helicopter Weighing	6-28
Weight and Balance—Weight-Shift Control Aircraft and Powered Parachutes.....	6-28
Weight-Shift Control Aircraft	6-28
Powered Parachutes.....	6-30
Built-In Electronic Weighing	6-30
Mean Aerodynamic Chord	6-30
Weight and Balance Records	6-32

Chapter 7

Aircraft Materials, Hardware, and Processes ..	7-1
Properties of Metals.....	7-2
Hardness	7-2
Strength.....	7-2
Density	7-2
Malleability	7-2
Ductility	7-2
Elasticity	7-2
Toughness	7-2
Brittleness	7-2
Fusibility.....	7-2
Conductivity	7-2
Thermal Expansion.....	7-2

Ferrous Aircraft Metals	7-3	Heat Treatment of Titanium.....	7-26
Iron.....	7-3	Stress Relieving	7-26
Steel and Steel Alloys.....	7-3	Full Annealing	7-26
Electrochemical Test.....	7-5	Thermal Hardening.....	7-26
Nonferrous Aircraft Metals	7-6	Casehardening.....	7-26
Aluminum and Aluminum Alloys	7-6	Hardness Testing.....	7-26
Wrought Aluminum.....	7-7	Brinell Tester	7-26
Effect of Alloying Element.....	7-8	Rockwell Tester	7-27
Hardness Identification.....	7-9	Barcol Tester.....	7-28
Magnesium and Magnesium Alloys	7-9	Forging	7-29
Titanium and Titanium Alloys.....	7-10	Casting.....	7-29
Copper and Copper Alloys	7-11	Extruding	7-29
Nickel and Nickel Alloys.....	7-12	Cold Working/Hardening	7-29
Substitution of Aircraft Metals.....	7-12	Nonmetallic Aircraft Materials	7-30
Metalworking Processes.....	7-12	Wood	7-30
Hot Working	7-12	Plastics.....	7-30
Internal Structure of Metals	7-14	Transparent Plastics.....	7-30
Heat-Treating Equipment	7-15	Composite Materials.....	7-31
Heating.....	7-16	Advantages/Disadvantages of Composites.....	7-31
Soaking	7-16	Composite Safety.....	7-32
Cooling	7-16	Fiber Reinforced Materials	7-32
Quenching Media.....	7-17	Laminated Structures	7-32
Quenching Equipment	7-19	Reinforced Plastic.....	7-32
Heat Treatment of Ferrous Metals.....	7-19	Rubber	7-33
Behavior of Steel During Heating and Cooling....	7-19	Natural Rubber.....	7-33
Hardening	7-19	Synthetic Rubber	7-33
Hardening Precautions.....	7-19	Shock Absorber Cord	7-34
Tempering.....	7-20	Seals	7-34
Annealing.....	7-20	Packings	7-35
Normalizing	7-20	O-Ring Packings.....	7-35
Casehardening.....	7-20	V-Ring Packings.....	7-36
Heat Treatment of Nonferrous Metals.....	7-21	U-Ring Packings.....	7-36
Aluminum Alloys	7-21	Gaskets	7-36
Alclad Aluminum	7-22	Wipers	7-36
Solution Heat Treatment.....	7-22	Sealing Compounds.....	7-37
Quenching.....	7-22	One Part Sealants.....	7-37
Lag Between Soaking and Quenching	7-23	Two Part Sealants	7-37
Reheat Treatment.....	7-23	Aircraft Hardware	7-37
Straightening After Solution Heat Treatment	7-23	Identification	7-37
Precipitation Heat Treating	7-23	Threaded Fasteners.....	7-38
Precipitation Practices	7-24	Classification of Threads	7-38
Annealing of Aluminum Alloys.....	7-24	Aircraft Bolts.....	7-39
Heat Treatment of Aluminum Alloy Rivets.....	7-24	General Purpose Bolts	7-39
Heat Treatment of Magnesium Alloys	7-25	Close Tolerance Bolts.....	7-39
Solution Heat Treatment.....	7-25	Internal Wrenching Bolts.....	7-39
Precipitation Heat Treatment.....	7-26	Identification and Coding	7-39
		Special-Purpose Bolts.....	7-41

Aircraft Nuts.....	7-43	Riveted and Rivetless Nut Plates.....	7-68
Non-Self-Locking Nuts	7-44	Nut Plates.....	7-68
Self-Locking Nuts.....	7-44	Rivnuts.....	7-69
Sheet Spring Nuts	7-46	Dill Lok-Skrus and Dill Lok-Rivets	7-70
Internal and External Wrenching Nuts	7-46	Deutsch Rivets	7-71
Identification and Coding	7-47	Sealing Nut Plates.....	7-71
Aircraft Washers.....	7-48	Hole Repair and Hole Repair Hardware.....	7-71
Plain Washers	7-48	Repair of Damaged Holes with Acres Fastener	
Lock Washers	7-48	Sleeves	7-71
Special Washers.....	7-48	Control Cables and Terminals	7-72
Installation of Nuts, Washers, and Bolts	7-48	Push-Pull Tube Linkage	7-75
Bolt and Hole Sizes	7-48	Safetying Methods.....	7-75
Installation Practices	7-49	Pins	7-76
Safetying of Bolts and Nuts	7-49	Safety Wiring	7-76
Repair of Damaged Internal Threads.....	7-49	Nuts, Bolts, and Screws	7-76
Fastener Torque.....	7-51	Oil Caps, Drain Cocks, and Valves	7-77
Torque.....	7-51	Electrical Connectors.....	7-77
Torque Wrenches.....	7-51	Turnbuckles	7-77
Torque Tables	7-52	General Safety Wiring Rules.....	7-80
Cotter Pin Hole Line Up.....	7-52	Cotter Pin Safetying.....	7-80
Aircraft Rivets	7-52	Snap Rings	7-81
Standards and Specifications	7-52		
Solid Shank Rivets.....	7-54	Chapter 8	
Identification.....	7-56	Cleaning and Corrosion Control.....	8-1
Blind Rivets	7-57	Corrosion.....	8-1
Mechanically-Expanded Rivets.....	7-58	Factors Affecting Corrosion.....	8-2
Self-Plugging Rivets (Friction Lock)	7-58	Pure Metals	8-2
Pull-Thru Rivets.....	7-59	Climate.....	8-2
Self-Plugging Rivets (Mechanical Lock)	7-60	Geographical Location.....	8-3
Material.....	7-61	Foreign Material	8-3
Head Styles	7-61	Micro-organisms.....	8-3
Diameters.....	7-61	Manufacturing Processes	8-3
Grip Length.....	7-62	Types of Corrosion.....	8-4
Rivet Identification	7-63	Direct Chemical Attack	8-4
Special Shear and Bearing Load Fasteners	7-63	Electrochemical Attack.....	8-5
Pin Rivets.....	7-64	Forms of Corrosion	8-6
Taper-Lok	7-64	Surface Corrosion	8-7
Hi-Tigue.....	7-65	Filiform Corrosion.....	8-7
Captive Fasteners.....	7-65	Pitting Corrosion.....	8-7
Turn Lock Fasteners	7-65	Dissimilar Metal Corrosion	8-7
Dzus Fasteners	7-65	Concentration Cell Corrosion.....	8-7
Camloc Fasteners.....	7-66	Intergranular Corrosion	8-9
Airloc Fasteners	7-66	Exfoliation Corrosion	8-9
Screws	7-67	Stress-Corrosion/Cracking.....	8-9
Structural Screws	7-67	Fretting Corrosion.....	8-10
Machine Screws.....	7-67	Fatigue Corrosion	8-10
Self-Tapping Screws.....	7-68	Galvanic Corrosion.....	8-11
Identification and Coding for Screws	7-68	Common Corrosive Agents.....	8-11

Preventive Maintenance.....	8-11	Interior Cleaning.....	8-25
Inspection.....	8-12	Types of Cleaning Operations	8-25
Corrosion Prone Areas.....	8-12	Nonflammable Aircraft Cabin Cleaning	
Exhaust Trail Areas.....	8-12	Agents and Solvents	8-25
Battery Compartments and Battery Vent		Flammable and Combustible Agents.....	8-26
Openings.....	8-12	Container Controls.....	8-26
Bilge Areas.....	8-13	Fire Prevention Precautions.....	8-26
Lavatories, Buffets, and Galleys	8-13	Fire Protection Recommendations.....	8-26
Wheel Well and Landing Gear.....	8-13	Powerplant Cleaning.....	8-27
Water Entrapment Areas	8-13	Solvent Cleaners	8-27
Engine Frontal Areas and Cooling Air Vents	8-13	Dry Cleaning Solvent	8-28
Wing Flap and Spoiler Recesses	8-14	Aliphatic and Aromatic Naphtha.....	8-28
External Skin Areas.....	8-14	Safety Solvent	8-28
Electronic and Electrical Compartments.....	8-14	Methyl Ethyl Ketone (MEK).....	8-28
Miscellaneous Trouble Areas.....	8-14	Kerosene.....	8-28
Corrosion Removal	8-15	Cleaning Compound for Oxygen Systems	8-28
Surface Cleaning and Paint Removal.....	8-15	Emulsion Cleaners	8-28
Fairing or Blending Reworked Areas.....	8-16	Water Emulsion Cleaner	8-28
Corrosion of Ferrous Metals	8-17	Solvent Emulsion Cleaners	8-28
Mechanical Removal of Iron Rust.....	8-17	Soaps and Detergent Cleaners	8-28
Chemical Removal of Rust.....	8-17	Cleaning Compound, Aircraft Surfaces	8-29
Chemical Surface Treatment of Steel.....	8-18	Nonionic Detergent Cleaners	8-29
Removal of Corrosion from Highly Stressed		Mechanical Cleaning Materials	8-29
Steel Parts.....	8-18	Mild Abrasive Materials.....	8-29
Corrosion of Aluminum and Aluminum Alloys	8-18	Abrasive Papers.....	8-29
Treatment of Unpainted Aluminum Surfaces	8-18	Chemical Cleaners	8-29
Treatment of Anodized Surfaces.....	8-19	Phosphoric-citric Acid.....	8-29
Treatment of Intergranular Corrosion in			
Heat-Treated Aluminum Alloy Surfaces.....	8-19		
Corrosion of Magnesium Alloys.....	8-20		
Treatment of Wrought Magnesium Sheet			
and Forgings.....	8-20		
Treatment of Installed Magnesium Castings.....	8-20		
Treatment of Titanium and Titanium Alloys.....	8-21		
Protection of Dissimilar Metal Contacts.....	8-21		
Contacts Not Involving Magnesium.....	8-21		
Contacts Involving Magnesium.....	8-21		
Corrosion Limits	8-22		
Processes and Materials Used in Corrosion Control....	8-22		
Metal Finishing	8-22		
Surface Preparation	8-22		
Chemical Treatments	8-22		
Anodizing	8-22		
Alodizing.....	8-23		
Chemical Surface Treatment and Inhibitors.....	8-23		
Chromic Acid Inhibitor	8-23		
Sodium Dichromate Solution	8-23		
Chemical Surface Treatments	8-24		
Protective Paint Finishes.....	8-24		
Aircraft Cleaning	8-24		
Exterior Cleaning	8-24		
		Chapter 9	
		Fluid Lines and Fittings	9-1
		Introduction.....	9-1
		Rigid Fluid Lines	9-2
		Tubing Materials	9-2
		Copper.....	9-2
		Aluminum Alloy Tubing	9-2
		Steel	9-2
		Titanium 3AL-2.5V	9-2
		Material Identification.....	9-2
		Sizes	9-2
		Fabrication of Metal Tube Lines.....	9-2
		Tube Cutting	9-3
		Tube Bending.....	9-3
		Alternative Bending Methods	9-5
		Tube Flaring.....	9-5
		Instructions for Rolling-Type Flaring Tools	9-6
		Double Flaring.....	9-6
		Double Flaring Instructions	9-7
		Fittings	9-7
		Flareless Fittings.....	9-7
		Beading	9-7

Fluid Line Identification.....	9-8	Progressive Inspections.....	10-12
Fluid Line End Fittings	9-9	Continuous Inspections	10-14
Universal Bulkhead Fittings	9-9	Altimeter and Transponder Inspections	10-14
AN Flared Fittings	9-9	Airlines for America iSpec 2200	10-14
MS Flareless Fittings.....	9-12	Special Inspections.....	10-15
Swaged Fittings	9-12	Hard or Overweight Landing Inspection.....	10-16
Cryofit Fittings.....	9-14	Severe Turbulence Inspection/Over “G”.....	10-16
Rigid Tubing Installation and Inspection	9-14	Lightning Strike.....	10-16
Connection and Torque.....	9-15	Bird Strike	10-16
Flareless Tube Installation.....	9-16	Fire Damage	10-17
Rigid Tubing Inspection and Repair.....	9-16	Flood Damage	10-17
Flexible Hose Fluid Lines.....	9-17	Seaplanes	10-17
Hose Materials and Construction	9-17	Aerial Application Aircraft	10-17
Buna-N.....	9-18	Special Flight Permits	10-17
Neoprene.....	9-18	Nondestructive Inspection/Testing	10-18
Butyl	9-18	Training, Qualification, and Certification	10-18
Hose Identification.....	9-18	Advantages and Disadvantages of NDI	
Flexible Hose Inspection.....	9-19	Methods.....	10-18
Fabrication and Replacement of Flexible Hose	9-19	Visual Inspection.....	10-18
Flexible Hose Testing	9-20	Surface Cracks	10-18
Size Designations	9-20	Borescope	10-18
Hose Fittings	9-20	Interpretation of Results	10-20
Installation of Flexible Hose Assemblies.....	9-20	False Indications	10-21
Slack	9-20	Eddy Current Inspection.....	10-21
Flex	9-22	Basic Principles	10-21
Twisting	9-22	Principles of Operations.....	10-21
Bending.....	9-22	Eddy Current Instruments	10-22
Clearance	9-22	Ultrasonic Inspection.....	10-23
Hose Clamps	9-22	Pulse Echo	10-25
		Through Transmission	10-26
		Resonance	10-26
		Ultrasonic Instruments	10-28
		Reference Standards.....	10-29
		Couplants.....	10-29
		Inspection of Bonded Structures.....	10-29
		Types of Defects.....	10-29
		Acoustic Emission Inspection	10-29
		Magnetic Particle Inspection	10-30
		Development of Indications.....	10-30
		Types of Discontinuities Disclosed	10-30
		Preparation of Parts for Testing.....	10-31
		Effect of Flux Direction.....	10-31
		Effect of Flux Density	10-32
		Magnetizing Methods.....	10-32
		Identification of Indications.....	10-32
		Magnaglo Inspection	10-33
		Magnetizing Equipment.....	10-33
		Indicating Mediums	10-34
		Demagnetizing.....	10-34
Chapter 10			
Inspection Concepts and Techniques.....	10-1		
Basic Inspection	10-2		
Techniques/Practices	10-2		
Preparation.....	10-2		
Aircraft Logs	10-2		
Checklists	10-2		
Publications.....	10-4		
Manufacturers’ Service Bulletins/Instructions	10-4		
Maintenance Manual	10-4		
Overhaul Manual.....	10-4		
Structural Repair Manual	10-4		
Illustrated Parts Catalog	10-4		
Wiring Diagram Manual	10-4		
Code of Federal Regulations (CFRs)	10-5		
Airworthiness Directives (ADs).....	10-5		
Type Certificate Data Sheets (TCDS).....	10-5		
Routine/Required Inspections.....	10-12		
Preflight/Postflight Inspections	10-12		
Annual/100-Hour Inspections	10-12		

Standard Demagnetizing Practice.....	10-35
Radiographic.....	10-35
Radiographic Inspection.....	10-35
Preparation and Exposure.....	10-35
Radiographic Interpretation.....	10-36
Radiation Hazards.....	10-37
Inspection of Composites.....	10-37
Tap Testing.....	10-37
Electrical Conductivity.....	10-37
Thermography.....	10-38
Inspection of Welds.....	10-38

Chapter 11

Hand Tools and Measuring Devices.....11-1

General Purpose Tools.....	11-2
Hammers and Mallets.....	11-2
Screwdrivers.....	11-2
Pliers and Plier-Type Cutting Tools.....	11-3
Punches.....	11-4
Wrenches.....	11-5
Special Wrenches.....	11-6
Torque Wrench.....	11-8
Strap Wrenches.....	11-8
Impact Drivers.....	11-8
Metal Cutting Tools.....	11-8
Hand Snips.....	11-8
Hacksaws.....	11-9
Chisels.....	11-10
Files.....	11-10
Care and Use.....	11-11
Most Commonly Used Files.....	11-11
Care of Files.....	11-12
Drills.....	11-12
Twist Drills.....	11-13
Reamers.....	11-14
Countersink.....	11-14
Taps and Dies.....	11-17
Layout and Measuring Tools.....	11-18
Rules.....	11-19
Combination Sets.....	11-19
Scriber.....	11-19
Dividers and Pencil Compasses.....	11-19
Calipers.....	11-22
Micrometer Calipers.....	11-23
Micrometer Parts.....	11-23
Reading a Micrometer.....	11-24
Vernier Scale.....	11-24
Using a Micrometer.....	11-25
Slide Calipers.....	11-25

Chapter 12

Fundamentals of Electricity and

Electronics.....12-1

Introduction.....	12-1
General Composition of Matter.....	12-2
Matter.....	12-2
Element.....	12-2
Compound.....	12-2
Molecule.....	12-2
Atom.....	12-2
Electrons, Protons, and Neutrons.....	12-2
Electron Shells and Energy Levels.....	12-3
Valence Electrons.....	12-4
Ions.....	12-4
Free Electrons.....	12-4
Electron Movement.....	12-4
Conductors, Insulators, and Semiconductors.....	12-4
Conductors.....	12-4
Insulators.....	12-4
Semiconductors.....	12-4
Metric Based Prefixes Used for Electrical	
Calculations.....	12-4
Static Electricity.....	12-5
Attractive and Repulsive Forces.....	12-5
Electrostatic Field.....	12-5
Electrostatic Discharge (ESD) Considerations.....	12-7
Magnetism.....	12-8
Types of Magnets.....	12-12
Electromagnetism.....	12-12
Conventional Flow and Electron Flow.....	12-16
Conventional Flow.....	12-16
Electron Flow.....	12-16
Electromotive Force (Voltage).....	12-16
Current.....	12-17
Ohm's Law (Resistance).....	12-18
Resistance of a Conductor.....	12-19
Factors Affecting Resistance.....	12-19
Resistance and Relation to Wire Sizing.....	12-20
Circular Conductors (Wires/Cables).....	12-20
Rectangular Conductors (Bus Bars).....	12-21
Power and Energy.....	12-21
Power in an Electrical Circuit.....	12-21
Power Formulas Used in the Study of	
Electricity.....	12-22
Power in a Series and Parallel Circuit.....	12-23
Energy in an Electrical Circuit.....	12-23
Sources of Electricity.....	12-23
Pressure Source.....	12-23
Chemical Source.....	12-23
Thermal Sources.....	12-23
Light Sources.....	12-24

Schematic Representation of Electrical Components.....	12-24	Alternating Current (AC) and Voltage	12-44
Conductors.....	12-24	AC and DC Compared	12-44
Types of Resistors.....	12-25	Generator Principles.....	12-44
Fixed Resistor.....	12-25	Generators of Alternating Current.....	12-46
Carbon Composition	12-25	Position 1	12-47
Resistor Ratings.....	12-25	Position 2	12-47
Color Code.....	12-25	Position 3	12-47
Color Band Decoding.....	12-25	Position 4	12-47
Wire-Wound.....	12-27	Position 5	12-47
Variable Resistors.....	12-27	Cycle and Frequency	12-47
Rheostat	12-27	Cycle Defined	12-47
Potentiometer	12-27	Frequency Defined.....	12-47
Thermistors.....	12-29	Period Defined	12-49
Photoconductive Cells.....	12-29	Wavelength Defined	12-49
Circuit Protection Devices	12-29	Phase Relationships	12-49
Fuse	12-29	In Phase Condition.....	12-49
Current Limiter.....	12-30	Out of Phase Condition.....	12-49
Circuit Breaker	12-30	Values of Alternating Current	12-50
Arc Fault Circuit Breaker	12-30	Instantaneous Value.....	12-50
Thermal Protectors	12-30	Peak Value	12-50
Control Devices.....	12-30	Effective Value	12-50
Switches	12-31	Opposition to Current Flow of AC.....	12-51
Toggle Switch.....	12-31	Capacitance	12-51
Microswitches.....	12-32	Capacitors in Direct Current.....	12-51
Rotary Selector Switches.....	12-33	The Resistor/Capacitor (RC) Time Constant	12-51
Pushbutton Switches	12-33	Units of Capacitance	12-52
Lighted Pushbutton Switches	12-33	Voltage Rating of a Capacitor	12-52
Dual In-Line Parallel (DIP) Switches.....	12-34	Factors Affecting Capacitance	12-52
Switch Guards.....	12-34	Types of Capacitors.....	12-53
Relays	12-34	Fixed Capacitors	12-53
Series DC Circuits.....	12-34	Ceramic	12-53
Voltage Drops and Further Application of Ohm's Law	12-36	Electrolytic	12-53
Voltage Sources in Series.....	12-36	Tantalum.....	12-54
Kirchhoff's Voltage Law.....	12-37	Polyester Film	12-54
Voltage Dividers.....	12-38	Oil Capacitors.....	12-54
Determining the Voltage Divider Formula	12-40	Variable Capacitors	12-54
Parallel DC Circuits	12-40	Trimmers	12-54
Voltage Drops.....	12-41	Varactors	12-54
Total Parallel Resistance	12-41	Capacitors in Series.....	12-55
Resistors in Parallel.....	12-41	Capacitors in Parallel.....	12-55
Two Resistors in Parallel.....	12-41	Capacitors in Alternating Current	12-56
Current Source.....	12-41	Capacitive Reactance X_c	12-56
Kirchhoff's Current Law	12-42	Sample Problem:	12-56
Current Dividers	12-42	Solution:	12-56
Series-Parallel DC Circuits	12-43	Capacitive Reactances in Series and in Parallel.....	12-57
Determining the Total Resistance	12-43	Phase of Current and Voltage in Reactive Circuits	12-57

Inductance	12-57	Wattmeter	12-77
Characteristics of Inductance	12-57	Frequency Measurement/Oscilloscope.....	12-78
The RL Time Constant	12-58	Horizontal Deflection	12-78
Physical Parameters.....	12-58	Vertical Deflection	12-79
Self-Inductance.....	12-59	Tracing a Sine Wave	12-79
Types of Inductors.....	12-59	Control Features on an Oscilloscope.....	12-79
Units of Inductance	12-59	Flat Panel Color Displays for Oscilloscopes.....	12-81
Inductors in Series	12-59	Digital Multimeter.....	12-81
Inductors in Parallel.....	12-59	Basic Circuit Analysis and Troubleshooting	12-81
Inductive Reactance	12-60	Voltage Measurement.....	12-82
AC Circuits	12-61	Current Measurement.....	12-82
Ohm's Law for AC Circuits	12-61	Checking Resistance in a Circuit.....	12-82
Series AC Circuits	12-61	Continuity Checks	12-83
Solution:.....	12-62	Capacitance Measurement.....	12-83
Solution:.....	12-62	Inductance Measurement.....	12-84
Solution:.....	12-63	Troubleshooting Open Faults in a Series	
Parallel AC Circuits.....	12-63	Circuit.....	12-84
Solution:.....	12-64	Tracing Opens with the Voltmeter	12-84
Solution:.....	12-64	Tracing Opens with the Ohmmeter	12-85
Resonance.....	12-64	Troubleshooting Shorting Faults in a Series	
Power in AC Circuits	12-65	Circuit.....	12-85
True Power Defined	12-65	Tracing Shorts with the Ohmmeter	12-86
Apparent Power Defined	12-66	Tracing Shorts with the Voltmeter	12-86
Solution:.....	12-66	Troubleshooting Open Faults in a Parallel	
Transformers	12-66	Circuit.....	12-86
Current Transformers	12-69	Tracing an Open with an Ammeter	12-87
Transformer Losses	12-69	Tracing an Open with an Ohmmeter	12-87
Power in Transformers	12-69	Troubleshooting Shorting Faults in Parallel	
DC Measuring Instruments	12-69	Circuits	12-87
D'Arsonval Meter Movement	12-69	Troubleshooting Shorting Faults in	
Current Sensitivity and Resistance.....	12-70	Series-Parallel Circuits	12-88
Damping	12-70	Logic in Tracing an Open	12-88
Electrical Damping.....	12-70	Tracing Opens with the Voltmeter	12-89
Mechanical Damping	12-70	Batteries	12-89
A Basic Multirange Ammeter	12-71	Primary Cell	12-89
Precautions.....	12-71	Secondary Cell	12-89
The Voltmeter	12-72	Battery Ratings	12-91
Voltmeter Sensitivity.....	12-72	Life Cycle of a Battery	12-91
Multiple Range Voltmeters	12-72	Lead-Acid Battery Testing Methods.....	12-91
Voltmeter Circuit Connections.....	12-72	Lead-Acid Battery Charging Methods	12-92
Influence of the Voltmeter in the Circuit	12-72	Nickel-Cadmium Batteries.....	12-93
The Ohmmeter	12-72	Chemistry and Construction.....	12-93
Zero Adjustment.....	12-73	Operation of Nickel-Cadmium Cells.....	12-93
Ohmmeter Scale	12-73	General Maintenance and Safety Precautions	12-94
The Multirange Ohmmeter.....	12-74	Sealed Lead Acid (SLA) Batteries	12-94
Megger (Megohmmeter)	12-74	Lithium Ion Batteries	12-94
AC Measuring Instruments	12-75	Inverters	12-95
Electrodynamometer Meter Movement.....	12-76	Rotary Inverters.....	12-95
Moving Iron Vane Meter.....	12-76	Permanent Magnet Rotary Inverter	12-95
Inclined Coil Iron Vane Meter	12-77	Inductor-Type Rotary Inverter	12-96
Varmeters	12-77	Static Inverters.....	12-97

Semiconductors.....	12-98	Impedance Coupling.....	12-118
Doping.....	12-99	Transformer Coupling.....	12-119
PN Junctions and the Basic Diode.....	12-100	Feedback.....	12-119
Forward Biased Diode.....	12-102	Operational Amplifiers (OP AMP).....	12-119
Reverse Biased Diode.....	12-103	Applications.....	12-120
Rectifiers.....	12-103	Magnetic Amplifiers.....	12-120
Half-Wave Rectifier.....	12-104	Saturable-Core Reactor.....	12-121
Full-Wave Rectifier.....	12-105	Logic Circuits.....	12-122
Dry Disk.....	12-105	Logic Polarity.....	12-122
Types of Diodes.....	12-106	Positive.....	12-122
Power Rectifier Diodes.....	12-106	Negative.....	12-122
Zener Diodes.....	12-106	Pulse Structure.....	12-122
Special Purpose Diodes.....	12-107	Basic Logic Circuits.....	12-123
Light-Emitting Diode (LED).....	12-107	The Inverter Logic.....	12-123
Liquid Crystal Displays (LCD).....	12-107	The AND Gate.....	12-123
Photodiode.....	12-107	The OR Gate.....	12-124
Varactors.....	12-107	The NAND Gate.....	12-125
Schottky Diodes.....	12-107	The NOR Gate.....	12-125
Diode Identification.....	12-107	Exclusive OR Gate.....	12-125
Introduction to Transistors.....	12-107	Exclusive NOR Gate.....	12-126
Classification.....	12-108	The Integrated Circuit.....	12-126
Transistor Theory.....	12-108	Microprocessors.....	12-127
PNP Transistor Operation.....	12-109	DC Generators.....	12-127
Identification of Transistors.....	12-109	Theory of Operation.....	12-127
Field Effect Transistors.....	12-110	Generation of a DC Voltage.....	12-129
Metal-Oxide-Semiconductor FET (MOSFET)....	12-110	Position A.....	12-129
Common Transistor Configurations.....	12-111	Position B.....	12-130
Common-Emitter (CE) Configuration.....	12-111	Position C.....	12-130
Common-Collector (CC) Configuration.....	12-112	Position D.....	12-130
Common-Base (CB) Configuration.....	12-112	The Neutral Plane.....	12-130
Vacuum Tubes.....	12-112	Construction Features of DC Generators.....	12-131
Filtering.....	12-112	Field Frame.....	12-131
Filtering Characteristics of Capacitors.....	12-112	Armature.....	12-132
Filtering Characteristics of Inductors.....	12-113	Gramme-Ring Armature.....	12-132
Common Filter Configurations.....	12-113	Drum-Type Armature.....	12-132
Basic LC Filters.....	12-114	Commutators.....	12-133
Low-Pass Filter.....	12-114	Armature Reaction.....	12-134
High-Pass Filter (HPF).....	12-114	Compensating Windings.....	12-134
Band-Pass Filter.....	12-115	Interpoles.....	12-134
Band-Stop Filter.....	12-115	Types of DC Generators.....	12-135
Amplifier Circuits.....	12-116	Series Wound DC Generators.....	12-135
Classification.....	12-116	Shunt Wound DC Generators.....	12-135
Class A.....	12-116	Compound Wound DC Generators.....	12-136
Class AB.....	12-117	Generator Ratings.....	12-137
Class B.....	12-117	Generator Terminals.....	12-137
Class C.....	12-118	DC Generator Maintenance.....	12-137
Methods of Coupling.....	12-118	Inspection.....	12-137
Direct Coupling.....	12-118	Condition of Generator Brushes.....	12-138
RC Coupling.....	12-118		

DC Motors	12-139	Starter Generator	12-161
Force Between Parallel Conductors	12-140	Alternator Rating	12-161
Developing Torque.....	12-140	Alternator Maintenance.....	12-161
Basic DC Motor	12-141	Regulation of Generator Voltage	12-162
Position A	12-142	Voltage Regulation with a Vibrating-Type	
Position B.....	12-142	Regulator	12-162
Position C.....	12-142	Three Unit Regulators	12-163
Position D	12-142	Differential Relay Switch.....	12-164
DC Motor Construction	12-142	Overvoltage and Field Control Relays	12-165
Armature Assembly.....	12-142	Generator Control Units (GCU).....	12-165
Field Assembly.....	12-142	Basic Functions of a Generator Control	
Brush Assembly	12-142	Unit (GCU).....	12-165
End Frame	12-143	Voltage Regulation.....	12-165
Types of DC Motors	12-144	Overvoltage Protection.....	12-166
Series DC Motor.....	12-144	Parallel Generator Operations	12-166
Shunt DC Motor	12-144	Over-Excitation Protection.....	12-166
Compound DC Motor.....	12-145	Differential Voltage.....	12-166
Counter Electromotive Force (emf)	12-145	Reverse Current Sensing	12-166
Types of Duty.....	12-146	Alternator Constant Speed Drive System	12-166
Reversing Motor Direction.....	12-146	Hydraulic Transmission	12-167
Motor Speed	12-147	Voltage Regulation of Alternators	12-174
Energy Losses in DC Motors.....	12-147	Alternator Transistorized Regulators	12-174
Inspection and Maintenance of DC Motors	12-148		
AC Motors	12-149	Chapter 13	
Types of AC Motors.....	12-149	Mechanic Privileges and Limitations.....	13-1
Three-Phase Induction Motor.....	12-149	Introduction.....	13-1
Rotating Magnetic Field.....	12-149	Mechanic Certification: Subpart A—General	
Construction of Induction Motor.....	12-150	(by 14 CFR Section)	13-2
Induction Motor Slip	12-150	Mechanic Certification: Subpart D—Mechanics	
Single-Phase Induction Motor.....	12-151	(by 14 CFR Section)	13-4
Shaded Pole Induction Motor.....	12-151	Inspection Authorization (IA).....	13-5
Split-Phase Motor.....	12-152	(by 14 CFR Section)	13-5
Capacitor Start Motor	12-152	Ethics.....	13-7
Direction of Rotation of Induction Motors.....	12-152	A Scenario	13-7
Synchronous Motor	12-152	Final Observation.....	13-8
AC Series Motor.....	12-154		
Maintenance of AC Motors	12-156	Chapter 14	
Alternators.....	12-156	Human Factors	14-1
Basic Alternators and Classifications.....	12-156	Introduction.....	14-1
Method of Excitation.....	12-156	FAA Involvement.....	14-1
Number of Phases.....	12-156	Importance of Human Factors	14-2
Armature or Field Rotation	12-156	Definitions of Human Factors	14-2
Single-Phase Alternator	12-157	What are Human Factors?.....	14-4
Two-Phase Alternator	12-158	Elements of Human Factors	14-4
Three-Phase Alternator.....	12-158	Clinical Psychology	14-4
Wye Connection (Three-Phase)	12-158	Experimental Psychology	14-4
Delta Connection (Three Phase).....	12-158	Anthropometry.....	14-5
Alternator Rectifier Unit	12-158	Computer Science.....	14-5
Brushless Alternator.....	12-159	Cognitive Science	14-6
Alternator Frequency.....	12-159	Safety Engineering.....	14-6

Medical Science.....	14-6
Organizational Psychology.....	14-6
Educational Psychology.....	14-7
Industrial Engineering.....	14-7
History of Human Factors.....	14-7
Evolution of Maintenance Human Factors.....	14-9
The Pear Model.....	14-10
People.....	14-10
Environment.....	14-11
Physical.....	14-11
Organizational.....	14-11
Actions.....	14-11
Resources.....	14-11
Human Error.....	14-14
Types of Errors.....	14-14
Unintentional.....	14-14
Intentional.....	14-14
Active and Latent.....	14-14
The “Dirty Dozen”.....	14-14
Lack of Communication.....	14-15
Complacency.....	14-16
Lack of Knowledge.....	14-16
Distraction.....	14-16
Lack of Teamwork.....	14-18
Fatigue.....	14-19
Lack of Resources.....	14-22
Lack of Assertiveness.....	14-25
Stress.....	14-27
Physical Stressors.....	14-28
Psychological Stressors.....	14-28
Physiological Stressors.....	14-28
Lack of Awareness.....	14-28
Norms.....	14-28
Example of Common Maintenance Errors.....	14-30
Where to Get Information.....	14-32
Federal Aviation Administration (FAA).....	14-32
FAA’s Maintenance Fatigue Section.....	14-32
FAA Safety Team.....	14-32
Other Resources.....	14-32
Decoding Human Factors.....	14-32
System Safety Services.....	14-33
Human Factors and Ergonomics Society (HFES).....	14-34
International Ergonomics Association (IEA).....	14-34

Glossary.....	G-1
----------------------	------------

Index.....	I-1
-------------------	------------

Chapter 1

Safety, Ground Operations, and Servicing

Aircraft maintenance technicians (AMTs) devote a portion of their aviation career to ground handling and operating aircraft. Technicians also need to be proficient in operating ground support equipment. The complexity of support equipment and the hazards involved in the ground handling of aircraft require that maintenance technicians possess a detailed knowledge of safety procedures used in aircraft servicing, taxiing, run-up, and in the use of ground support equipment. The information provided in this chapter is intended as a general guide for safely servicing and operating aircraft.

Introducing human factors to aircraft maintenance personnel makes them aware of how it affects maintenance performance. Although there are many human factors involved when dealing with maintenance performance, several areas can be considered. Some of these include fatigue, deadline pressure, stress, distractions, poor communication skills, complacency, and lack of information. Maintenance technicians need to understand how human factors can impact their performance and safety while completing maintenance tasks.



Lights	Meaning
Flashing green	Cleared to taxi
Steady red	Stop
Flashing red	Taxi clear of runway in use
Flashing white	Return to starting point
Alternating red and green	Exercise extreme caution



Shop Safety

Keeping the shop, hangars, and flight line clean is essential to safety and efficient maintenance. The highest standards of orderly work arrangements and cleanliness must be observed during the maintenance of aircraft. Where continuous work shifts are established, the outgoing shift removes and properly stores personal tools, rollaway boxes, work stands, maintenance stands, hoses, electrical cords, hoists, crates, and boxes that were needed for the work to be accomplished.

Signs are posted to indicate dangerous equipment or hazardous conditions. Additionally, there are signs that provide the location of first aid and fire equipment. Safety lanes, pedestrian walkways, and fire lanes are painted around the perimeter inside the hangars. This is a safety measure to prevent accidents and to keep pedestrian traffic out of work areas.

Safety is everyone's business. However, technicians and supervisors must watch for their own safety and for the safety of others working around them. Communication is key to ensuring everyone's safety. If other personnel are conducting their actions in an unsafe manner, communicate with them, reminding them of their safety and that of others around them.

Electrical Safety

Physiological Safety

Working with electrical equipment poses certain physiological safety hazards. When electricity is applied to the human body, it can create severe burns in the area of entrance and at the point of exit from the body. In addition, the nervous system is affected and can be damaged or destroyed. To safely deal with electricity, the technician must have a working knowledge of the principles of electricity and a healthy respect for its capability to do both work and damage.

Wearing or use of proper safety equipment can provide a psychological assurance and physically protect the user at the same time. The use of rubber gloves, safety glasses, rubber or grounded safety mats, and other safety equipment contributes to the overall safety of the technician working on or with electrical equipment.

Two factors that affect safety when dealing with electricity are fear and overconfidence. These two factors are major causes of accidents involving electricity. While a certain amount of respect for electrical equipment is healthy and a certain level of confidence is necessary, extremes of either can be deadly.

Lack of respect is often due to lack of knowledge. Personnel who attempt to work with electrical equipment and have no knowledge of the principles of electricity lack the skills

to deal with electrical equipment safely. Overconfidence leads to risk taking. The technician who does not respect the capabilities of electricity will, sooner or later, become a victim of electricity's power.

Fire Safety

Anytime current flows, whether during generation or transmission, a by-product is heat. The greater the current flow, the greater the amount of heat created. When this heat becomes too great, protective coatings on wiring and other electrical devices can melt, causing shorting. That in turn leads to more current flow and greater heat. This heat can become so great that metals can melt, liquids vaporize, and flammable substances ignite.

An important factor in preventing electrical fires is to keep the area around electrical work or electrical equipment clean, uncluttered, and free of all unnecessary flammable substances. Ensure that all power cords, wires, and lines are free of kinks and bends that can damage the wire. Never place wires or cords where they may be walked on or run over by other equipment. When several wires inside a power cord are broken, the current passing through the remaining wires increases. This generates more heat than the insulation coatings on the wire are designed to withstand and can lead to a fire. Closely monitor the condition of electrical equipment. Repair or replace damaged equipment before further use.

Safety Around Compressed Gases

Compressed air, like electricity, is an excellent tool when it is under control. A typical nitrogen bottle set is shown in *Figure 1-1*. The following "dos and don'ts" apply when working with or around compressed gases:

- Inspect air hoses frequently for breaks and worn spots. Unsafe hoses must be replaced immediately.
- Keep all connections in a "no-leak condition."
- Maintain in-line oilers, if installed, in operating condition.
- Ensure the system has water sumps installed and drained at regular intervals.
- Filter air used for paint spraying to remove oil and water.
- Never use compressed air to clean hands or clothing. Pressure can force debris into the flesh leading to infection.
- Never spray compressed air in the area of other personnel.
- Straighten, coil, and properly store air hoses when not in use.



Figure 1-1. A typical nitrogen bottle.

- Many accidents involving compressed gases occur during aircraft tire mounting. To prevent possible personal injury, use tire dollies and other appropriate devices to mount or remove heavy aircraft tires.

When inflating tires on any type of aircraft wheels, always use tire cage guards. Extreme caution is required to avoid over inflation of high-pressure tires because of possible personal injury. Use pressure regulators on high-pressure air bottles to eliminate the possibility of over inflation of tires. Tire cages are not required when adjusting pressure in tires installed on an aircraft.

Safety Around Hazardous Materials

Material safety diamonds are important with regard to shop safety. These diamond-shaped labels are a simple and quick way to determine the risk of hazardous material within the associated container and, if used properly with the tags, indicate what personal safety equipment to use.

The most observable portion of the Safety Data Sheets (SDS) (formerly known as Material Safety Data Sheet (MSDS))

label is the risk diamond. It is a four-color segmented diamond that represents flammability (red), reactivity (yellow), health (blue), and special hazard (white). In the flammability, reactivity, and health blocks, there is a number from 0 to 4. Zero represents little or no hazard to the user, while 4 means that the material is very hazardous. The special hazard segment contains a word or abbreviation to represent the specific hazard. Some examples are RAD for radiation, ALK for alkali materials, Acid for acidic materials, and CARC for carcinogenic materials. The letter W with a line through it stands for high reactivity to water. [Figure 1-2]

The SDS is a more detailed version of the chemical safety issues. These forms have the detailed breakdown of the chemicals, including formulas and action to take if personnel come in contact with the chemicals. All sheets have the same information requirements; however, the exact location of the information on the sheet may vary depending on the SDS manufacturer. These forms are necessary for a safe shop that meets all the requirements of the governing safety body, the U.S. Department of Labor Occupational Safety and Health Administration (OSHA).

Safety Around Machine Tools

Hazards in a shop increase when the operation of lathes, drill presses, grinders, and other types of machines are used. Each machine has its own set of safety practices. The following discussions are necessary to avoid injury.

The drill press can be used to bore and ream holes, to do facing, milling, and other similar types of operations. The

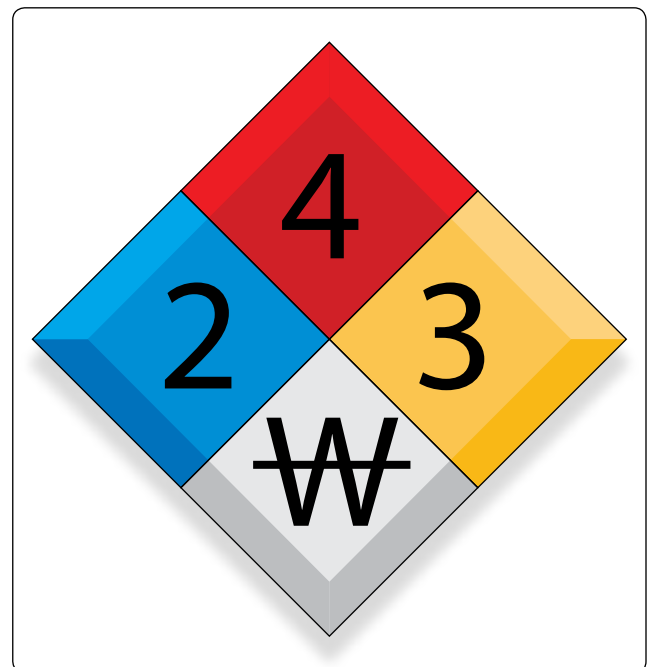

Figure 1-2. A risk diamond.

following precautions can reduce the chance of injury:

- Wear eye protection.
- Securely clamp all work.
- Set the proper revolutions per minute (RPM) for the material used.
- Do not allow the spindle to feed beyond its limit of travel while drilling.
- Stop the machine before adjusting work or attempting to remove jammed work.
- Clean the area when finished.

Lathes are used in turning work of a cylindrical nature. This work may be performed on the inside or outside of the cylinder. The work is secured in the chuck to provide the rotary motion, and the forming is done by contact with a securely mounted tool. The following precautions can reduce the chance of injury:

- Wear eye protection.
- Use sharp cutting tools.
- Allow the chuck to stop on its own. Do not attempt to stop the chuck by hand pressure.
- Examine tools and work for cracks or defects before starting the work.
- Do not set tools on the lathe. Tools may be caught by the work and thrown.
- Before measuring the work, allow it to stop in the lathe.

Milling machines are used to shape or dress; cut gear teeth, slots, or key ways; and similar work. The following precautions can reduce the chance of injury:

- Wear eye protection.
- Clean the work bed prior to work.
- Secure the work to the bed to prevent movement during milling.
- Select the proper tools for the job.
- Do not change the feed speed while working.
- Lower the table before moving under or away from the work.
- Ensure all clamps and bolts are passable under the arbor.

Grinders are used to sharpen tools, dress metal, and perform other operations involving the removal of small amounts of metal. The following precautions can reduce the chance of injury:

- Wear eye protection, even if the grinder has a shield.
- Inspect the grinding wheel for defects prior to use.
- Do not force grinding wheels onto the spindle. They fit snugly but do not require force to install them. Placing side pressure on a wheel could cause it to explode.
- Check the wheel flanges and compression washer. They should be one-third the diameter of the wheel.
- Do not stand in the arc of the grinding wheel while operating in case the wheel explodes.

Welding must be performed only in designated areas. Any part that is to be welded must be removed from the aircraft, if possible. Repair would then be accomplished in a controlled environment, such as a welding shop. A welding shop must be equipped with proper tables, ventilation, tool storage, and fire prevention and extinguishing equipment.

Welding on an aircraft should be performed outside, if possible. If welding in the hangar is necessary, observe these precautions:

- During welding operations, open fuel tanks and work on fuel systems are not permitted.
- Painting is not permitted.
- No aircraft are to be within 35 feet of the welding operation.
- No flammable material is permitted in the area around the welding operation.
- Only qualified welders are permitted to do the work.
- The welding area is to be roped off and placarded.
- Fire extinguishing equipment of a minimum rating of 20B must be in the immediate area with 80B rated equipment as a backup.
- Trained fire watches are to be present in the area around the welding operation.
- The aircraft being welded must be in a towable condition, with a tug attached, and the aircraft parking brakes released. A qualified operator must be on the tug and mechanics available to assist in the towing operation should it become necessary to tow the aircraft. If the aircraft is in the hangar, the hangar doors are to be open.

Flight Line Safety

Hearing Protection

The flight line is a place of dangerous activity. Technicians who perform maintenance on the flight line must constantly be aware of what is going on around them. The noise on a flight line comes from many places. Aircraft are only one

source of noise. There are auxiliary power units (APUs), fuel trucks, baggage handling equipment, and so forth. Each has its own frequency of sound. Combined all together, the noise on the ramp or flight line can cause hearing loss.

There are many types of hearing protection available. Hearing protection can be external or internal. Earmuffs or headphones are considered external protection. The internal type of hearing protection fits into the auditory canal. Both types reduce the sound level reaching the eardrum and reduce the chances of hearing loss.

Hearing protection is essential when working with pneumatic drills, rivet guns, or other loud tools. Even short duration exposure to these sounds can cause hearing loss because of their high frequency. Continued exposure will cause hearing loss.

Foreign Object Damage (FOD)

Foreign object damage (FOD) is any damage to aircraft, personnel, or equipment caused by any loose object. These loose objects can be anything, such as broken runway concrete, shop towels, safety wire, etc. To control FOD, keep ramp and operation areas clean, have a tool control program, and provide convenient receptacles for used hardware, shop towels, and other consumables.

Never leave tools or other items around the intake of a turbine engine. The modern gas turbine engine creates a low-pressure area in front of the engine that causes any loose object to be drawn into the engine. The exhaust of these engines can propel loose objects great distances with enough force to damage anything that is hit. The importance of a FOD program cannot be overstressed when a technician considers the cost of engines, components, or a human life.

Safety Around Airplanes

As with the previously mentioned items, it is important to be aware of propellers. Technicians cannot assume the pilot of a taxiing aircraft can see them and must stay within the pilot's view while on the ramp area. Turbine engine intakes and exhaust can also be very hazardous areas. Smoking or open flames are not permitted anywhere near an aircraft in operation. Be aware of aircraft fluids that can be detrimental to skin. When operating support equipment around aircraft, be sure to allow space between it and the aircraft, and secure it so it cannot roll into the aircraft. All items in the area of operating aircraft must be stowed properly.

Safety Around Helicopters

Every type of helicopter has different features. These differences must be learned to avoid damaging the helicopter or injuring the technician. When approaching a helicopter

while the blades are turning, adhere to the following guidelines to ensure safety.

- Observe the rotor head and blades to see if they are level. This allows maximum clearance when approaching the helicopter.
- Approach the helicopter in view of the pilot.
- Never approach a helicopter carrying anything with a vertical height that the blades could hit. This could cause blade damage and injury to the individual.
- Never approach a single-rotor helicopter from the rear. The tail rotor is invisible when operating.
- Never go from one side of the helicopter to the other by going around the tail. Always go around the nose of the helicopter.

When securing the rotor on helicopters with elastomeric bearings, check the maintenance manual for the proper method. Using the wrong method could damage the bearing.

Fire Safety

Performing maintenance on aircraft and their components requires the use of electrical tools that can produce sparks, heat-producing tools and equipment, flammable and explosive liquids, and gases. As a result, a high potential exists for fire to occur. Measures must be taken to prevent a fire from occurring and to have a plan for extinguishing it.

The key to fire safety is knowledge of what causes a fire, how to prevent it, and how to put it out. This knowledge must be instilled in each technician, emphasized by their supervisors through sound safety programs, and occasionally practiced. Airport or other local fire departments can normally be called upon to assist in training personnel and helping to establish fire safety programs for the hangar, shops, and flight line.

Fire Protection

Requirements for Fire to Occur

Three things are required for a fire. Remove any one of these things and the fire extinguishes:

1. Fuel—combines with oxygen in the presence of heat, releasing more heat. As a result, it reduces itself to other chemical compounds.
2. Heat—accelerates the combining of oxygen with fuel, in turn releasing more heat.
3. Oxygen—the element that combines chemically with another substance through the process of oxidation. Rapid oxidation, accompanied by a noticeable release of heat and light, is called combustion or burning.

[Figure 1-3]

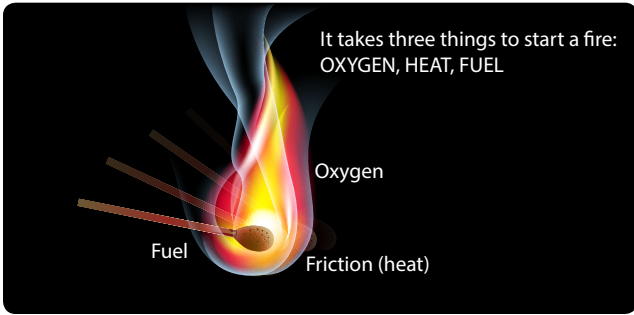

Figure 1-3. Three elements of fire.

Classification of Fires

For commercial purposes, the National Fire Protection Association (NFPA) has classified fires into three basic types: Class A, Class B, and Class C.

1. Class A fires involve ordinary combustible materials, such as wood, cloth, paper, upholstery materials, and so forth.
2. Class B fires involve flammable petroleum products or other flammable or combustible liquids, greases, solvents, paints, and so forth.
3. Class C fires involve energized electrical wiring and equipment.

A fourth class of fire, the Class D fire, involves flammable metal. Class D fires are not commercially considered by the NFPA to be a basic type of fire since they are caused by a Class A, B, or C fire. Usually Class D fires involve magnesium in the shop, or in aircraft wheels and brakes, or are the result of improper welding operations.

Any one of these fires can occur during maintenance on or around, or operations involving aircraft. There is a particular type of extinguisher that is most effective for each type of fire.

Types and Operation of Shop and Flight Line Fire Extinguishers

Water extinguishers are the best type to use on Class A fires. Water has two effects on fire. It deprives fire of oxygen and cools the material being burned.

Since most petroleum products float on water, water-type fire extinguishers are not recommended for Class B fires. Extreme caution must be used when fighting electrical fires (Class C) with water-type extinguishers. All electrical power must be removed or shut off to the burning area. Additionally, residual electricity in capacitors, coils, and so forth must be considered to prevent severe injury or possibly death from electrical shock.

Never use water-type fire extinguishers on Class D fires. The cooling effect of water causes an explosive expansion of the metal, because metals burn at extremely high temperatures.

Water fire extinguishers are operated in a variety of ways. Some are hand pumped, while others are pressurized. The pressurized types of extinguishers may have a gas charge stored in the container with the water, or it may contain a "soda-acid" container where acid is spilled into a container of soda inside the extinguisher. The chemical reaction of the soda and the acid causes pressure to build inside the fire extinguisher, forcing the water out.

Carbon dioxide (CO₂) extinguishers are used for Class A, B, and C fires, extinguishing the fire by depriving it of oxygen. [Figure 1-4] Additionally, like water-type extinguishers, CO₂ cools the burning material. Never use CO₂ on Class D fires. As with water extinguishers, the cooling effect of CO₂ on the hot metal can cause explosive expansion of the metal.



Figure 1-4. Carbon dioxide fire extinguisher.

When using CO₂ fire extinguishers, all parts of the extinguisher can become extremely cold, and remain so for a short time after operation. Wear protective equipment or take other precautions to prevent cold injury, such as frostbite. Extreme caution must be used when operating CO₂ fire extinguishers in closed or confined areas. Not only can the fire be deprived of oxygen, but so too can the operator.

CO₂ fire extinguishers generally use the self-expelling method of operation. This means that the CO₂ has sufficient pressure at normal operating pressure to expel itself. This

pressure is held inside the container by some type of seal or frangible disk that is broken or punctured by a firing mechanism, usually a pin. This means that once the seal or disk is broken, pressure in the container is released and the fire extinguisher is spent, requiring replacement. [Figure 1-5]

Halogenated hydrocarbon extinguishers are most effective on Class B and C fires. They can be used on Class A and D fires, but they are less effective. Halogenated hydrocarbon, commonly called Freon™ by the industry, are numbered according to chemical formulas with Halon™ numbers.

Extinguishing Materials	Classes of Fire				Self-Generating	Self-Expelling	Cartridge of N ₂ Cylinder	Stored Pressure	Pump	Hand
	A	B	B	D						
Water and antifreeze	X						X	X	X	X
Soda-acid (water)	X				X					
Wetting agent	X						X			
Foam	X	X			X					
Loaded stream	X	X+					X	X		
Multipurpose dry chemical	X+	X	X				X	X		
Carbon dioxide		X+	X			X				
Dry chemical		X	X				X	X		
Bromotrifluoromethane — Halon 1301		X	X			X				
Bromochlorodifluoromethane — Halon 1211		X	X					X		
Dry powder (metal fires)				X			X			X

+ Smaller sizes of these extinguishers are not recognized for use on these classes of fire.

Figure 1-5. Extinguisher operation and methods of expelling.

Group	Definition	Examples
6 (Least toxic)	Gases or vapors in concentrations up to 20% by volume, for durations of exposure of up to approximately 2 hours, do not appear to produce injury.	Bromotrifluoromethane (Halon 1301)
5a	Gases or vapors much less toxic than Group 4, but more toxic than Group 6.	Carbon dioxide
4	Gases or vapors in concentrations of the order of 2 to 2 ½%, for durations of exposure of up to approximately 2 hours are lethal or produce serious injury.	Dibromodifluoromethane (Halon 1202)
3	Gases or vapors in concentrations of the order of 2 to 2 ½%, for durations of exposure of the order of 1 hour are lethal or produce serious injury.	Bromochloromethane (Halon 1011) Carbon tetrachloride (Halon 104)
2	Gases or vapors in concentrations of approximately ½ to 1%, for durations of exposure of up to approximately ½ hour are lethal or produce serious injury.	Methyl bromide (Halon 1001)

Figure 1-6. Toxicity table.

Carbon tetrachloride (Halon 104), chemical formula CCl_4 , has an Underwriters Laboratory (UL) toxicity rating of 3. As such, it is extremely toxic. [Figure 1-6] Hydrochloric acid vapor, chlorine, and phosgene gas are produced whenever carbon tetrachloride is used on ordinary fires. The amount of phosgene gas is increased whenever carbon tetrachloride is brought in direct contact with hot metal, certain chemicals, or continuing electrical arcs. It is not approved for any fire extinguishing use. Old containers of Halon 104 found in or around shops or hangars should be disposed of in accordance with Environmental Protection Agency (EPA) regulations and local laws and ordinances.

Methyl bromide (Halon 1001), chemical formula CH_3Br , is a liquefied gas with a UL toxicity rating of 2. It is very toxic and corrosive to aluminum alloys, magnesium, and zinc. Halon 1001 is not recommended for aircraft use. Chlorobromomethane (Halon 1011), chemical formula CH_2ClBr , is a liquefied gas with a UL toxicity rating of 3. Like methyl bromide, Halon 1011 is not recommended for aircraft use. Dibromodifluoromethane (Halon 1202), chemical formula CBr_2F_2 , has a UL toxicity rating of 4. Halon 1202 is not recommended for aircraft use.

Bromochlorodifluoromethane (Halon 1211), chemical formula CBrClF_2 , is a liquefied gas with a UL toxicity rating of 5. It is colorless, noncorrosive, and evaporates rapidly leaving no residue. It does not freeze or cause cold burns and does not harm fabrics, metals, or other materials it contacts. Halon 1211 acts rapidly on fires by producing a heavy blanketing mist that eliminates oxygen from the fire source. More importantly, it interferes chemically with the combustion process of the fire. Furthermore, it has outstanding properties in preventing re-flash after the fire has been extinguished.

Bromotrifluoromethane (Halon 1301), chemical formula CF_3Br , is also a liquefied gas and has a UL toxicity rating of 6. It has all the characteristics of Halon 1211. The significant difference between the two is Halon 1211 forms a spray similar to CO_2 , while Halon 1301 has a vapor spray that is more difficult to direct.

Note: The EPA has restricted Halon to its 1986 production level due to its effect on the ozone layer.

Dry powder extinguishers, while effective on Class B and C fires, are best for use on Class D fires. The method of operation of dry powder fire extinguishers varies from gas cartridge charges, stored pressure within the container that forces the powder charge out of the container, to scooping pails or buckets of the powder from large containers or barrels to toss on the fire.

Dry powder is not recommended for aircraft use, except on metal fires, as a fire extinguisher. The leftover chemical residues and dust often make cleanup difficult and can damage electronic or other delicate equipment.

Inspection of Fire Extinguishers

Fire extinguishers need to be checked periodically utilizing a checklist. If a checklist is unavailable, check the following as a minimum:

- Proper location of appropriate extinguisher
- Safety seals unbroken
- All external dirt and rust removed
- Gauge or indicator in operable range
- Proper weight
- No nozzle obstruction
- No obvious damage

Airport or other local fire departments can usually help in preparing or providing extinguisher checklists. In addition, these fire departments can be helpful in answering questions and assisting in obtaining repairs to or replacement of fire extinguishers.

Identifying Fire Extinguishers

Fire extinguishers are marked to indicate suitability for a particular class of fire. The markings on *Figure 1-7* must be placed on the fire extinguisher and in a conspicuous place in the vicinity of the fire extinguisher. When the location is marked, however, take extreme care to ensure that the fire extinguisher kept at that location is in fact the type depicted by the marking. In other words, if a location is marked for a Class B fire extinguisher, ensure that the fire extinguisher in that location is in fact suitable for Class B fires.

Markings must be applied by decalcomanias (decals), painting, or similar methods. They are to be legible and as durable as necessary for the location. For example, markings used outside need to be more durable than those in the hangar or office spaces.

When markings are applied to the extinguisher, they are placed on the front of the shell, if one is installed, above or below the extinguisher nameplate. Markings must be large enough and in a form that is easily seen and identifiable by the average person with average eyesight at a distance of at least 3 feet.

When markings are applied to wall panels, and so forth, in the vicinity of extinguishers, they must be large enough and in a form that is easily seen and identifiable by the average

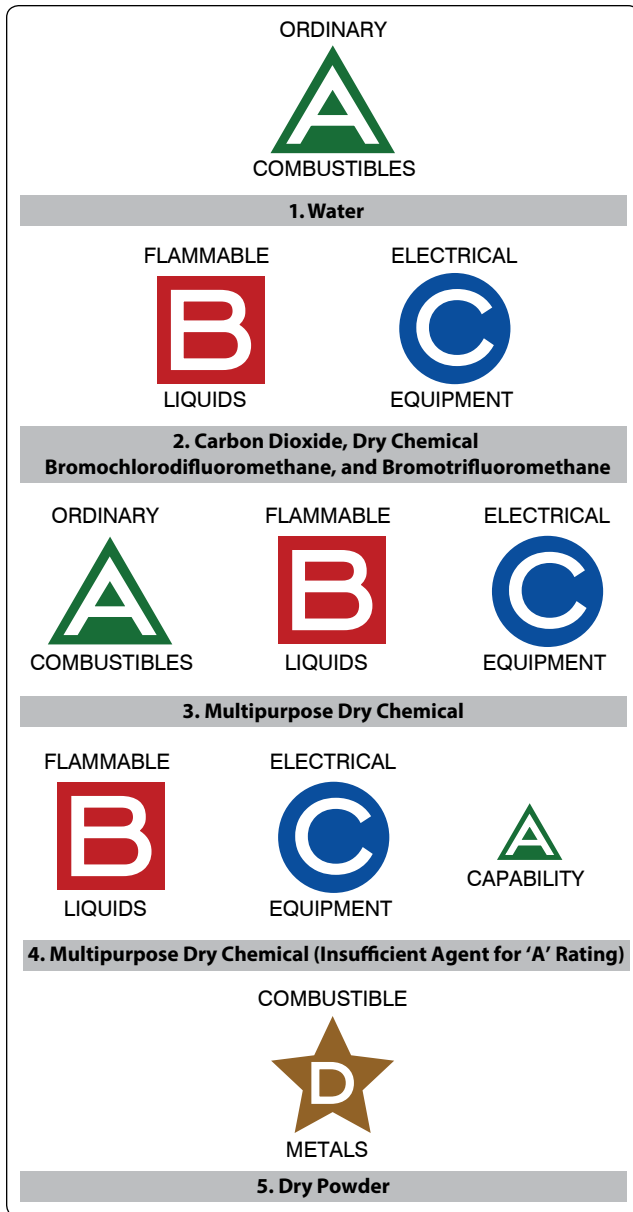

Figure 1-7. Typical extinguisher markings.

person with average eyesight at a distance of at least 25 feet. [Figure 1-8]

Using Fire Extinguishers

When using a fire extinguisher, ensure the correct type is used for the fire. Most extinguishers have a pin to pull that allows the handle to activate the agent. Stand back 8 feet and aim at the base of the fire or flames. Squeeze the lever and sweep side to side until the fire is extinguished.

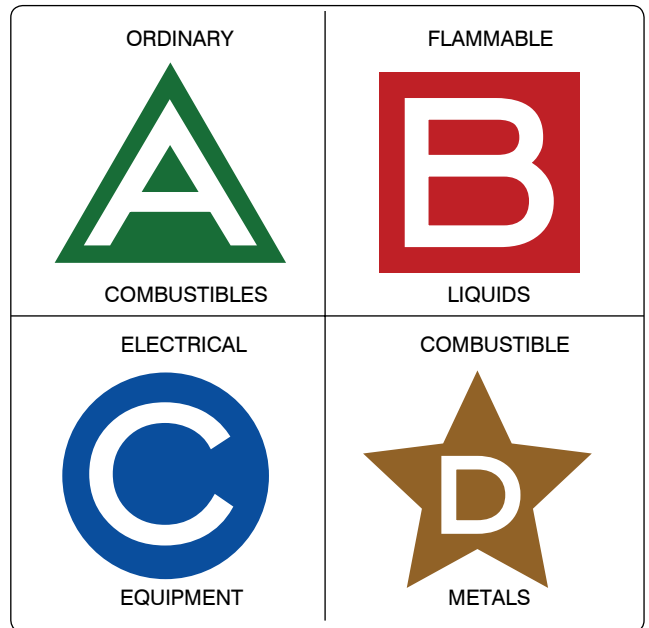

Figure 1-8. Identification of fire extinguisher type location.

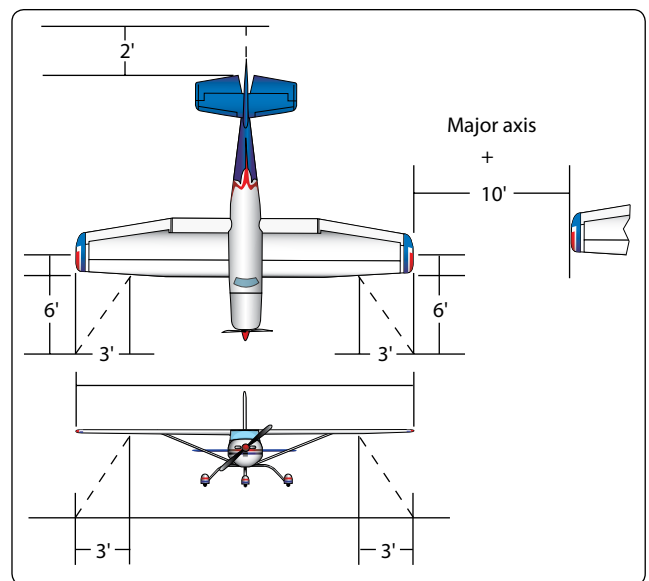

Figure 1-9. Diagram of tiedown dimensions.

Tie-Down Procedures

Preparation of Aircraft

Aircraft are to be tied down after each flight to prevent damage from sudden storms. The direction that aircraft are to be parked and tied down is determined by prevailing or forecast wind direction.

Aircraft are to be headed into the wind, depending on the locations of the parking area's fixed tie-down points. Spacing of tie-downs need to allow for ample wingtip clearance. [Figure 1-9] After the aircraft is properly located, lock the nosewheel or the tail wheel in the fore-and-aft position.

Tie-Down Procedures for Land Planes

Securing Light Aircraft

Light aircraft are most often secured with ropes tied only at the aircraft tie-down rings provided for securing purposes. Rope is never to be tied to a lift strut, since this practice can bend a strut if the rope slips to a point where there is no slack. Since manila rope shrinks when wet, about 1 inch (1") of slack needs to be provided for movement. Too much slack, however, allows the aircraft to jerk against the ropes. Tight tie-down ropes put inverted flight stresses on the aircraft and many are not designed to take such loads.

A tie-down rope holds no better than the knot. Anti-slip knots, such as the bowline, are quickly tied and are easy to untie. [Figure 1-10] Aircraft not equipped with tie-down fittings must be secured in accordance with the manufacturer's instructions. Ropes are to be tied to outer ends of struts on

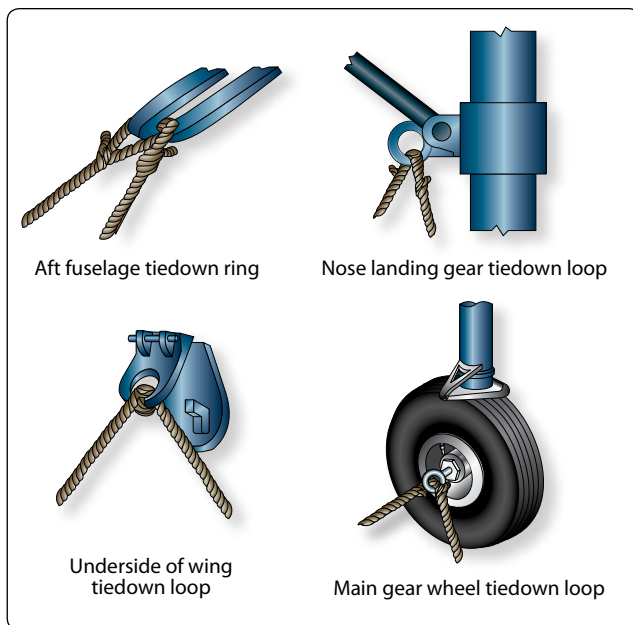

Figure 1-11. Common tie-down points.

high-wing monoplanes and suitable rings provided where structural conditions permit, if the manufacturer has not already provided them.

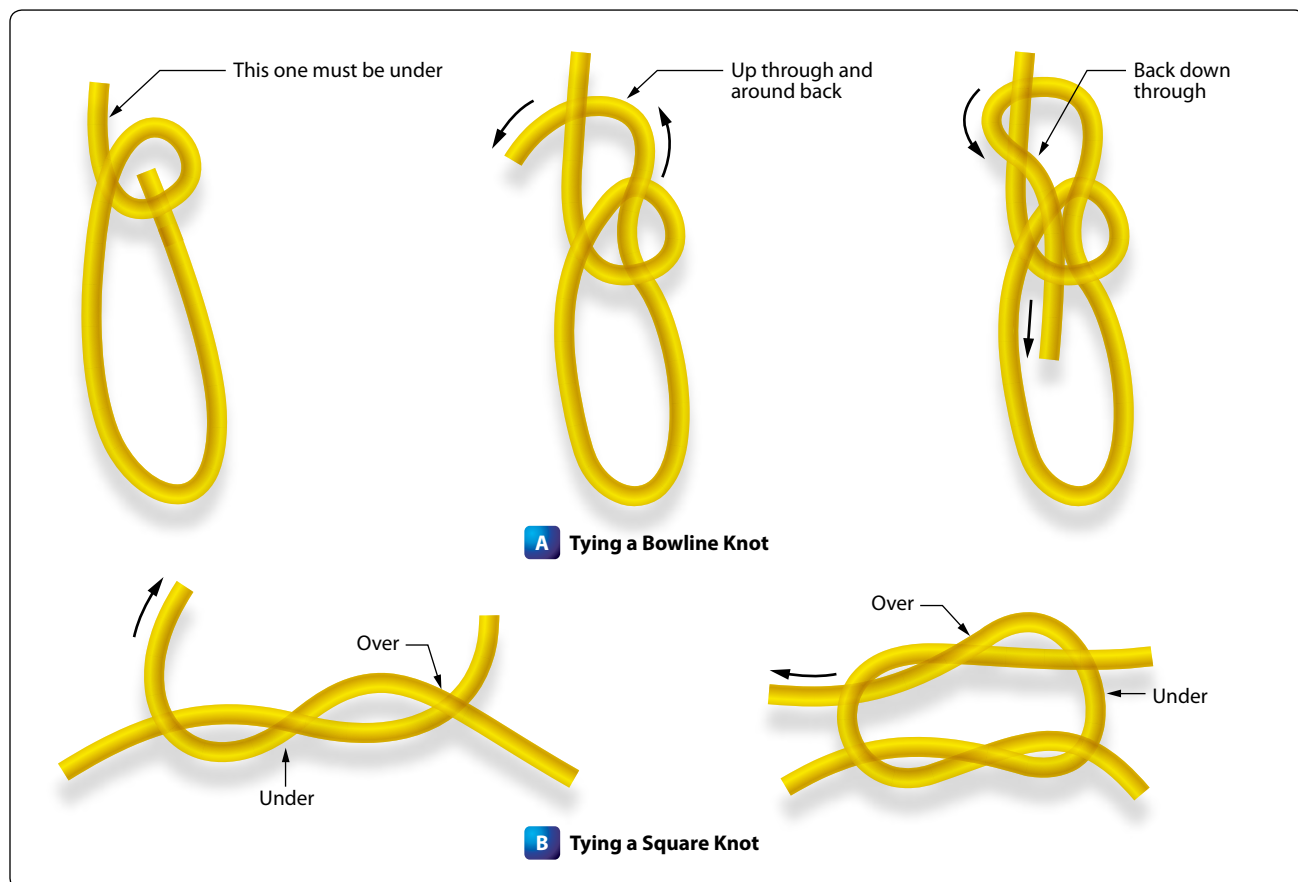

Figure 1-10. Knots commonly used for aircraft tie-down.



Figure 1-12. *Wheels chocked fore and aft.*

Securing Heavy Aircraft

The normal tie-down procedure for heavy aircraft can be accomplished with rope or cable tie-down. The number of tie-downs are governed by anticipated weather conditions.

Most heavy aircraft are equipped with surface control locks that are engaged or installed when the aircraft is secured. Since the method of locking controls vary on different types of aircraft, check the manufacturer's instructions for proper installation or engaging procedures. If high winds are anticipated, control surface battens can also be installed to prevent damage. *Figure 1-11* illustrates four common tie-down points on heavy aircraft.

The normal tie-down procedure for heavy aircraft includes the following:

1. Head airplane into prevailing wind whenever possible.
2. Install control locks, all covers, and guards.
3. Chock all wheels fore and aft. [*Figure 1-12*]
4. Attach tie-down reels to airplane tie-down loops, tie-down anchors, or tie-down stakes. Use tie-down stakes for temporary tie-down only. If tie-down reels are not available, ¼" wire cable or 1½" manila line may be used.

Tie-Down Procedures for Seaplanes

Seaplanes can be moored to a buoy, weather permitting, or tied to a dock. Weather causes wave action, and waves cause the seaplane to bob and roll. This bobbing and rolling while tied to a dock can cause damage.

When warning of an impending storm is received and it is not possible to fly the aircraft out of the storm area, some

compartments of the seaplane can be flooded, partially sinking the aircraft. Tie down the aircraft securely to anchors. Seaplanes tied down on land have been saved from high-wind damage by filling the floats with water in addition to tying the aircraft down in the usual manner. During heavy weather, if possible, remove the seaplane from the water and tie down in the same manner as a land plane. If this is not possible, the seaplane could be anchored in a sheltered area away from the wind and waves.

Tie-Down Procedures for Ski Planes

Ski planes are tied down, if the securing means are available, in the same manner as land planes. Ski-equipped airplanes can be secured on ice or in snow by using a device called a dead-man. A dead-man is any item at hand, such as a piece of pipe, log, and so forth, that a rope is attached to and buried in a snow or ice trench. Using caution to keep the free end of the rope dry and unfrozen, snow is packed in the trench. If available, pour water into the trench; when it is frozen, tie down the aircraft with the free end of the rope.

Operators of ski-equipped aircraft sometimes pack soft snow around the skis, pour water on the snow, and permit the skis to freeze to the ice. This, in addition to the usual tie-down procedures, aids in preventing damage from windstorms. Caution must be used when moving an aircraft that has been secured in this manner to ensure that a ski is not still frozen to the ground. Otherwise, damage to the aircraft or skis can occur.

Tie-Down Procedures for Helicopters

Helicopters, like other aircraft are secured to prevent structural damage that can occur from high-velocity surface winds. Helicopters are to be secured in hangars, when possible. If not, they must be tied down securely. Helicopters that are tied down can usually sustain winds up to approximately 65 mph. If at all possible, helicopters are evacuated to a safe area if tornadoes or hurricanes are anticipated. For added protection, helicopters can be moved to a clear area so that they are not damaged by flying objects or falling limbs from surrounding trees.

If high winds are anticipated with the helicopter parked in the open, tie down the main rotor blades. Detailed instructions for securing and mooring each type of helicopter can be found in the applicable maintenance manual. [*Figure 1-13*] Methods of securing helicopters vary with weather conditions, the length of time the aircraft is expected to remain on the ground, and location and characteristics of the aircraft. Wheel chocks, control locks, rope tie-downs, mooring covers, tip socks, tie-down assemblies, parking brakes, and rotor brakes are used to secure helicopters.

Typical mooring procedures are as follows:

1. Face the helicopter in the direction that the highest forecast wind or gusts are anticipated.



Figure 1-13. Example of mooring of a helicopter.

2. Spot the helicopter slightly more than one rotor span distance from other aircraft.
3. Place wheel chocks ahead of and behind all wheels (where applicable). On helicopters equipped with skids, retract the ground handling wheels, lower the helicopter to rest on the skids, and install wheel position lock pins or remove the ground-handling wheels. Secure ground-handling wheels inside the aircraft or inside the hangar or storage buildings. Do not leave them unsecured on the flight line.

4. Align the blades and install tie-down assemblies as prescribed by the helicopter manufacturer. [Figure 1-14] Tie straps snugly without strain, and during wet weather, provide some slack to avoid the possibility of the straps shrinking, causing undue stress on the aircraft and/or its rotor system(s).
5. Fasten the tie-down ropes or cables to the forward and aft landing gear cross tubes and secure to ground stakes or tie-down rings.

Procedures for Securing Weight-Shift-Control

There are many types of weight-shift-controlled aircraft—engine powered and non-powered. These types of aircraft are very susceptible to wind damage. The wings can be secured in a similar manner as a conventional aircraft in light winds. In high winds, the mast can be disconnected from the wing and the wing placed close to the ground and secured. This type of aircraft can also be partially disassembled or moved into a hangar for protection.

Procedures for Securing Powered Parachutes

When securing powered parachutes, pack the parachute in a bag to prevent the chute from filling with air from the wind and dragging the seat and engine. The engine and seat can also be secured if needed.

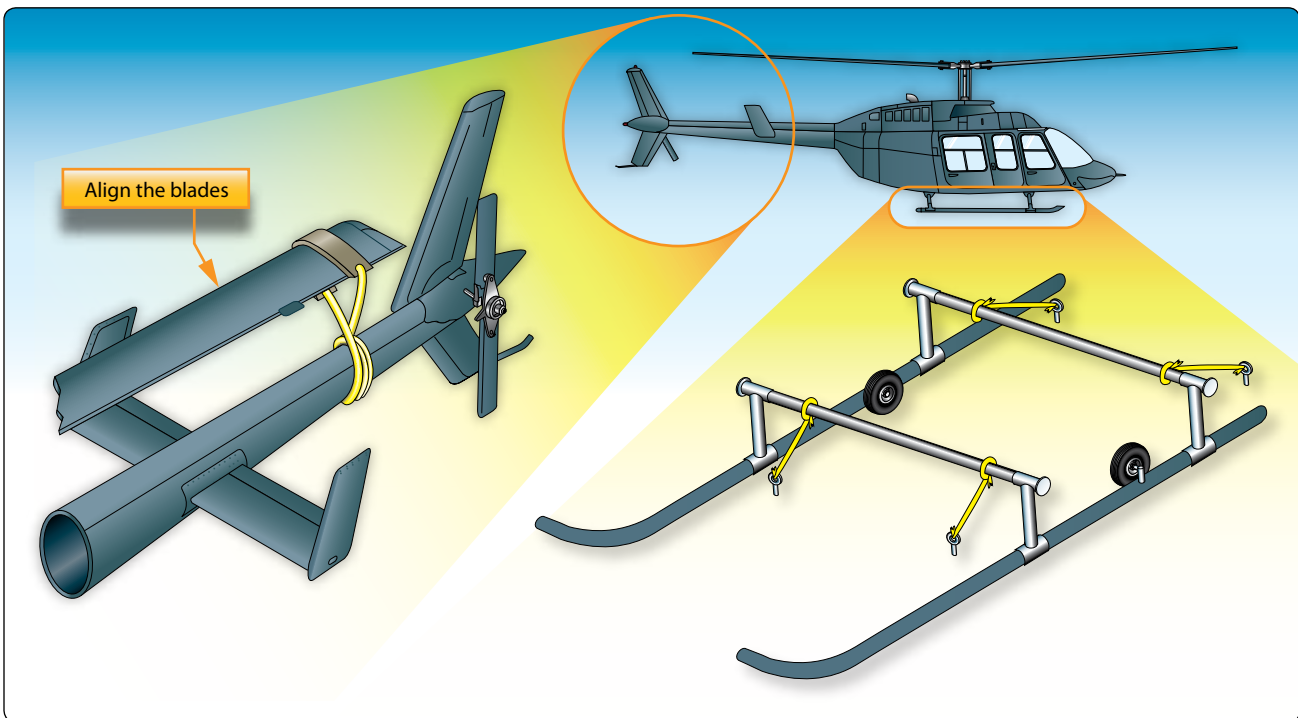

Figure 1-14. Securing helicopter blades and fuselage.

Aviation Maintenance Technician Handbook— General

FAA-H-8083-30A



U.S. Department
of Transportation
**Federal Aviation
Administration**

The *Aviation Maintenance Technician Handbook—General* is designed for use by instructors and applicants preparing for the FAA Knowledge and Practical Exams for obtaining an FAA Aviation Maintenance Technician (AMT) certificate with airframe or powerplant ratings, or both (also called an A&P license). This volume was developed as one in a series of handbooks for this purpose; additionally, it is an invaluable reference guide for already-certificated technicians and those holding the Inspection Authorization (IA) rating who wish to improve their knowledge.

This FAA handbook discusses the principles, fundamentals, and technical procedures in subject matter areas common to the airframe and powerplant ratings: safety, ground operations and servicing, regulations, maintenance forms, records and publications, mathematics, aircraft drawings, physics, weight and balance, aircraft materials, hardware

and processes, cleaning and corrosion control, fluid lines and fittings, inspection concepts and techniques, hand tools and measuring devices, electricity and electronics, inspection, mechanic privileges and limitations, and human factors. Also discussed are the ways that successful AMTs incorporate into their daily tasks the knowledge and awareness of ethics and professionalism. Illustrated throughout with detailed, full-color drawings and photographs, with a comprehensive glossary and index.

Also available in the FAA Aviation Maintenance
Technician Handbooks series:

Airframe, Volume 1 (ASA-8083-31V1)

Airframe, Volume 2 (ASA-8083-31V2)

Powerplant, Volumes 1 and 2 (ASA-8083-32)

Aviation Supplies & Academics, Inc. – Since 1940
Quality and Service You Can Depend On.

Reprinted by ASA



Aviation Supplies & Academics, Inc.
7005 132nd Place SE
Newcastle, Washington 98059
www.asa2fly.com | 425-235-1500

ASA-8083-30A