



FAA-H-8083-32B

Aviation Maintenance Technician Handbook – Powerplant



U.S. Department
of Transportation
Federal Aviation
Administration



Aviation Maintenance Technician Handbook–Powerplant

2023

U.S. Department of Transportation
Federal Aviation Administration
Flight Standards Service

Preface

The Aviation Maintenance Technician Handbook—Powerplant (FAA-H-8083-32B) is one of a series of three handbooks for persons preparing for certification as a powerplant mechanic. It is intended that this handbook provide the basic information on principles, fundamentals, and technical procedures in the subject matter areas relating to the powerplant rating. It is designed to aid students enrolled in a formal course of instruction, as well as the individual who is studying on his or her own. Since the knowledge requirements for the airframe and powerplant ratings closely parallel each other in some subject areas, the chapters which discuss fire protection systems and electrical systems contain some material which is also duplicated in the Aviation Maintenance Technician Handbook—Airframe (FAA-H-8083-31B).

This handbook contains an explanation of the units that make up each of the systems that bring fuel, air, and ignition together in an aircraft engine for combustion. It also contains information on engine construction features, lubrication systems, exhaust systems, cooling systems, cylinder removal and replacement, compression checks, and valve adjustments. Because there are so many different types of aircraft in use today, it is reasonable to expect that differences exist in airframe components and systems. To avoid undue repetition, the practice of using representative systems and units is carried out throughout the handbook. Subject matter treatment is from a generalized point of view and should be supplemented by reference to manufacturer's manuals or other textbooks if more detail is desired. This handbook is not intended to replace, substitute for, or supersede official regulations or the manufacturer's instructions. Occasionally the word "must" or similar language is used where the desired action is deemed critical. The use of such language is not intended to add to, interpret, or relieve a duty imposed by Title 14 of the Code of Federal Regulations (14 CFR).

The subject of Human Factors is contained in the Aviation Maintenance Technician Handbook—General (FAA-H-8083-30) (as revised).

This handbook is available for download, in PDF format, from www.faa.gov.

This handbook is published by the United States Department of Transportation, Federal Aviation Administration, Airman Testing Standards Branch, AFS-630, P.O. Box 25082, Oklahoma City, OK 73125.

Comments regarding this publication should be emailed to AFS630comments@faa.gov.

Acknowledgments

The Aviation Maintenance Technician Handbook–Powerplant (FAA-H-8083-32B) was produced by the Federal Aviation Administration (FAA). The FAA wishes to acknowledge the following contributors:

Mr. Tom Wild for images used throughout this handbook
Free Images Live (www.freeimageslive.co.uk) for image used in Chapter 1
Mr. Stephen Sweet (www.stephensweet.com) for image used in Chapter 1
Mr. Omar Filipovic (www.glasair-owners.com) for image used in Chapter 1
Mr. Warren Lane (Atomic Metalsmith, Inc.) for image used in Chapter 1
Pratt & Whitney for images used in Chapters 2, 3, 6, 7, and 8
Teledyne Continental Motors (www.genuinecontinental.aero) for images used in Chapters 2, 3, and 11
Aircraft Tool Supply Company (www.aircraft-tool.com) for images used in Chapter 4
Chief Aircraft (www.chiefaircraft.com) for images used in Chapter 4
DeltaHawk Engines, Inc. (www.deltahawkengines.com) for image used in Chapter 6
Mr. Felix Gottwald for image used in Chapter 7
Mr. Stephen Christopher (www.schristo.com) for images used in Chapter 8
Mr. Yunjin Lee for images used in Chapter 9
Mr. Marco Leerentveld (www.flightillusion.com) for image used in Chapter 10
Aeromax Aviation, LLC (www.aeromaxaviation.com) for images used in Chapter 11
Avid Aircraft (www.avidflyeraircraft.com) for image used in Chapter 11
Flight and Safety Design (www.ecolaircraft.com) for image used in Chapter 11
Great Plains Aircraft Supply Co., Inc. (www.greatplainsas.com) for image used in Chapter 11
Lycoming Engines (www.lycoming.textron.com) for image used in Chapter 11
Revmaster LLC Aviation (revmasteraviation.com) for images used in Chapter 11
Rotech Research Canada, Ltd. (www.rotec.com) for images used in Chapter 11

Additional appreciation is extended to Mr. Gary E. Hoyle, Dean of Students, Pittsburgh Institute of Aeronautics; Mr. Tom Wild, Purdue University; Dr. Ronald Sterkenburg, Associate Professor of the Department of Aviation Technology, Purdue University; for their technical support and input.

Table of Contents

Chapter 1

Aircraft Engines

General Requirements	1-1
Power & Weight	1-2
Fuel Economy	1-2
Durability & Reliability	1-2
Operating Flexibility	1-3
Compactness	1-3
Powerplant Selection	1-3
Types of Engines	1-3
Inline Engines	1-3
Opposed or O-Type Engines	1-4
V-Type Engines	1-4
Radial Engines	1-4
Reciprocating Engines	1-5
Design & Construction	1-5
Crankcase Section	1-5
Accessory Section	1-7
Accessory Gear Trains	1-7
Crankshafts	1-7
Crankshaft Balance	1-8
Dynamic Dampers	1-8
Connecting Rods	1-9
Master-and-Articulated Rod Assembly	1-9
Knuckle Pins	1-10
Plain-Type Connecting Rods	1-11
Fork-and-Blade Rod Assembly	1-11
Pistons	1-11
Piston Construction	1-12
Piston Pin	1-13
Piston Rings	1-13
Piston Ring Construction	1-13
Compression Ring	1-13
Oil Control Rings	1-13
Oil Scraper Ring	1-13
Cylinders	1-14
Cylinder Heads	1-14
Cylinder Barrels	1-15
Cylinder Numbering	1-15
Firing Order	1-16
Single-Row Radial Engines	1-16
Double-Row Radial Engines	1-16
Valves	1-16
Valve Construction	1-17
Valve Operating Mechanism	1-18
Cam Rings	1-18

Camshaft	1-20
Tappet Assembly.....	1-20
Solid Lifters/Tappets	1-20
Hydraulic Valve Tappets/Lifters.....	1-20
Push Rod	1-21
Rocker Arms	1-21
Valve Springs.....	1-21
Bearings	1-22
Plain Bearings.....	1-22
Ball Bearings.....	1-22
Roller Bearings	1-22
Propeller Reduction Gearing.....	1-23
Propeller Shafts.....	1-23
Reciprocating Engine Operating Principles.....	1-25
Operating Cycles.....	1-25
Four-Stroke Cycle	1-25
Intake Stroke.....	1-26
Compression Stroke	1-27
Power Stroke	1-27
Exhaust Stroke.....	1-27
Two-Stroke Cycle.....	1-27
Rotary Cycle	1-27
Diesel Cycle.....	1-27
Reciprocating Engine Power & Efficiencies	1-27
Work	1-27
Horsepower	1-28
Piston Displacement	1-28
Area of a Circle	1-28
Compression Ratio	1-29
Indicated Horsepower.....	1-30
Brake Horsepower	1-31
Friction Horsepower.....	1-32
Friction & Brake Mean Effective Pressures	1-33
Thrust Horsepower	1-33
Efficiencies	1-33
Thermal Efficiency	1-33
Mechanical Efficiency	1-35
Volumetric Efficiency.....	1-35
Propulsive Efficiency.....	1-36
Gas Turbine Engines	1-36
Types & Construction.....	1-36
Air Entrance	1-37
Accessory Section.....	1-38
Compressor Section.....	1-38
Compressor Types.....	1-38
Centrifugal-Flow Compressors	1-38
Axial-Flow Compressor.....	1-40
Diffuser.....	1-43
Combustion Section	1-43
Turbine Section.....	1-46
Exhaust Section.....	1-51

Gas Turbine Engine Bearings & Seals	1-52
Turboprop Engines	1-54
Turboshaft Engines	1-55
Turbofan Engines	1-55
Turbine Engine Operating Principles.....	1-56
Thrust	1-58
Gas Turbine Engine Performance	1-59
Ram Recovery	1-60

Chapter 2

Engine Fuel & Fuel Metering Systems

Fuel System Requirements	2-1
Vapor Lock	2-1
Basic Fuel System	2-2
Fuel Metering Devices for Reciprocating Engines	2-2
Air-Fuel Mixtures.....	2-3
Carburetion Principles	2-5
Venturi Principles	2-5
Application of Venturi Principle to Carburetor	2-5
Metering & Discharge of Fuel	2-6
Carburetor Systems	2-7
Carburetor Types.....	2-8
Carburetor Icing	2-8
Float-Type Carburetors	2-9
Float Chamber Mechanism System.....	2-10
Main Metering System	2-10
Idling System	2-12
Mixture Control System	2-12
Accelerating System	2-13
Economizer System.....	2-13
Pressure Injection Carburetors	2-14
Typical Injection Carburetor	2-15
Throttle Body	2-15
Regulator Unit.....	2-15
Fuel Control Unit.....	2-17
Automatic Mixture Control (AMC)	2-18
Stromberg PS Carburetor	2-19
Accelerating Pump.....	2-21
Manual Mixture Control.....	2-21
Fuel-Injection Systems	2-21
Bendix/Precision Fuel-Injection System	2-21
Fuel Injector	2-21
Airflow Section	2-21
Regulator Section	2-22
Fuel Metering Section.....	2-23
Flow Divider	2-23
Fuel Discharge Nozzles.....	2-24
Continental/TCM Fuel-Injection System	2-24
Fuel-Injection Pump.....	2-25
Air-Fuel Control Unit	2-25
Fuel Control Assembly.....	2-26

Fuel Manifold Valve	2-26
Fuel Discharge Nozzle.....	2-27
Carburetor Maintenance	2-27
Carburetor Removal	2-27
Installation of Carburetor	2-29
Rigging Carburetor Controls	2-29
Adjusting Idle Mixtures.....	2-29
Idle Speed Adjustment.....	2-30
Fuel System Inspection & Maintenance	2-31
Complete System	2-31
Fuel Tanks	2-32
Lines & Fittings	2-32
Selector Valves	2-32
Pumps.....	2-32
Main Line Strainers.....	2-32
Fuel Quantity Gauges.....	2-32
Fuel Pressure Gauge.....	2-32
Pressure Warning Signal	2-32
Water Injection Systems for Reciprocating Engines	2-33
Turbine Engine Fuel System—General Requirements	2-33
Turbine Fuel Controls	2-33
Hydromechanical Fuel Control	2-34
Hydromechanical/Electronic Fuel Control.....	2-34
FADEC Fuel Control Systems	2-36
FADEC for an Auxiliary Power Unit.....	2-36
FADEC Fuel Control Propulsion Engine	2-36
Fuel System Operation	2-40
Water Injection System	2-40
Fuel Control Maintenance	2-40
Engine Fuel System Components.....	2-41
Main Fuel Pumps (Engine Driven).....	2-41
Fuel Heater	2-42
Fuel Filters	2-42
Fuel Spray Nozzles & Fuel Manifolds.....	2-43
Simplex Fuel Nozzle	2-44
Duplex Fuel Nozzle.....	2-44
Airblast Nozzles	2-44
Flow Divider	2-45
Fuel Pressurizing & Dump Valves	2-45
Combustion Drain Valves	2-46
Fuel Quantity Indicating Units	2-46

Chapter 3

Induction & Exhaust Systems

Reciprocating Engine Induction Systems.....	3-1
Basic Carburetor Induction System	3-1
Induction System Icing.....	3-3
Induction System Filtering.....	3-4
Induction System Inspection & Maintenance	3-4
Extinguishing Engine Fires	3-4
Induction System Troubleshooting.....	3-5

Supercharged Induction Systems.....	3-5
Internally Driven Superchargers	3-6
Turbosuperchargers	3-7
Normalizer Turbocharger	3-9
Ground-Boosted Turbosupercharger System	3-9
A Typical Turbosupercharger System	3-10
Turbocharger Controllers & System Descriptions.....	3-14
Variable Absolute Pressure Controller (VAPC)	3-14
Sloped Controller	3-15
Absolute Pressure Controller	3-15
Turbocharger System Troubleshooting.....	3-15
Turbine Engine Inlet Systems	3-16
Divided-Entrance Duct.....	3-17
Variable-Geometry Duct	3-17
Compressor Inlet Screens	3-18
Bellmouth Compressor Inlets.....	3-19
Turboprop & Turboshaft Compressor Inlets.....	3-19
Turbofan Engine Inlet Sections.....	3-19
Reciprocating Engine Exhaust Systems	3-21
Radial Engine Exhaust Collector Ring System.....	3-22
Manifold & Augmentor Exhaust Assembly	3-22
Reciprocating Engine Exhaust System Maintenance Practices	3-22
Exhaust System Inspection	3-22
Muffler & Heat Exchanger Failures.....	3-23
Exhaust Manifold & Stack Failures	3-24
Internal Muffler Failures	3-24
Exhaust Systems with Turbocharger.....	3-24
Augmentor Exhaust System	3-24
Exhaust System Repairs	3-24
Turbine Engine Exhaust Nozzles.....	3-25
Convergent Exhaust Nozzle	3-26
Convergent-Divergent Exhaust Nozzle.....	3-26
Thrust Reversers.....	3-27
Afterburning/Thrust Augmentation	3-27
Thrust Vectoring	3-29
Engine Noise Suppression.....	3-29
Turbine Engine Emissions.....	3-31

Chapter 4

Engine Ignition & Electrical Systems

Reciprocating Engine Ignition Systems.....	4-1
Magneto-Ignition System Operating Principles	4-1
High-Tension Magneto System Theory of Operation.....	4-2
Magnetic Circuit	4-2
Primary Electrical Circuit.....	4-3
Secondary Electrical Circuit.....	4-6
Magneto & Distributor Venting	4-7
Ignition Harness.....	4-7
Ignition Switches.....	4-8
Single & Dual High-Tension System Magnetos	4-10

Magneto Mounting Systems	4-10
High- & Low-Tension Magneto Systems	4-11
Types of DC Generators	4-12
Series Wound DC Generators	4-12
Parallel (Shunt) Wound DC Generators.....	4-12
Compound Wound DC Generators	4-13
Generator Ratings	4-13
DC Generator Maintenance	4-13
FADEC System Description	4-14
Low-Voltage Harness.....	4-14
Electronic Control Unit (ECU)	4-15
PowerLink Ignition System	4-16
Engine Indicating & Crew Alerting System (EICAS)	4-16
Auxiliary Ignition Units	4-17
Booster Coil	4-18
Impulse Coupling	4-19
High-Tension Retard Breaker Vibrator	4-21
Low-Tension Retard Breaker Vibrator.....	4-23
Spark Plugs	4-24
Reciprocating Engine Ignition System Maintenance & Inspection.....	4-26
Magneto-Ignition Timing Devices	4-26
Built-In Engine Timing Reference Marks	4-26
Timing Discs	4-27
Piston Position Indicators	4-27
Timing Lights.....	4-28
Checking the Internal Timing of a Magneto.....	4-29
High-Tension Magneto E-Gap Setting (Bench Timing)	4-29
Timing the High-tension Magneto to the Engine.....	4-30
Performing Ignition System Checks.....	4-31
Ignition Switch Check	4-31
Maintenance & Inspection of Ignition Leads	4-31
Replacement of Ignition Harness.....	4-33
Checking Ignition Induction Vibrator Systems	4-33
Spark Plug Inspection & Maintenance	4-33
Carbon Fouling of Spark Plugs.....	4-33
Oil Fouling of Spark Plugs	4-34
Lead Fouling of Spark Plugs.....	4-34
Graphite Fouling of Spark Plugs.....	4-35
Gap Erosion of Spark Plugs	4-35
Spark Plug Removal	4-35
Spark Plug Reconditioning Service	4-36
Inspection Prior to Installation.....	4-37
Spark Plug Installation	4-38
Spark Plug Lead Installation	4-38
Breaker Point Inspection.....	4-39
Dielectric Inspection.....	4-41
Ignition Harness Maintenance	4-41
High-Tension Ignition Harness Faults	4-41
Harness Testing	4-42
Turbine Engine Ignition Systems.....	4-43
Capacitor Discharge Exciter Unit.....	4-44

Igniter Plugs.....	4-45
Turbine Ignition System Inspection & Maintenance	4-45
Inspection	4-45
Check System Operation.....	4-46
Repair	4-46
Removal, Maintenance, & Installation of Ignition System Components.....	4-46
Ignition System Leads	4-46
Igniter Plugs.....	4-47
Powerplant Electrical Systems.....	4-47
Wire Size	4-48
Factors Affecting the Selection of Wire Size.....	4-48
Factors Affecting Selection of Conductor Material.....	4-50
Voltage Drop in Aircraft Wire & Cable.....	4-50
Conductor Insulation.....	4-52
Identifying Wire & Cable	4-53
Electrical Wiring Installation.....	4-54
Wire Groups & Bundles	4-54
Twisting Wires.....	4-54
Spliced Connections in Wire Bundles.....	4-54
Slack in Wiring Bundles	4-54
Bend Radii	4-55
Routing & Installation.....	4-55
Protection Against Chafing	4-56
Protection Against High Temperature	4-56
Protection Against Solvents & Fluids.....	4-56
Protection of Wires in Wheel Well Area	4-57
Routing Precautions	4-57
Installation of Cable Clamps.....	4-57
Lacing & Tying Wire Bundles	4-58
Single-Cord Lacing	4-58
Double-Cord Lacing.....	4-59
Lacing Branch-Offs	4-59
Tying.....	4-59
Cutting Wire & Cable.....	4-60
Stripping Wire & Cable.....	4-61
Solderless Terminals & Splices.....	4-61
Copper Wire Terminals	4-62
Crimping Tools.....	4-62
Aluminum Wire Terminals	4-63
Splicing Copper Wires Using Preinsulated Wires.....	4-63
Emergency Splicing Repairs	4-63
Splicing with Solder & Potting Compound	4-63
Connecting Terminal Lugs to Terminal Blocks.....	4-64
Bonding & Grounding.....	4-65
General Bonding & Grounding Procedures	4-65
Connectors.....	4-67
Types of Connectors.....	4-67
Connector Identification	4-68
Installation of Connectors	4-69
Conduit.....	4-69
Electrical Equipment Installation	4-70

Electrical Load Limits.....	4-70
Controlling or Monitoring the Electrical Load.....	4-70
Circuit Protection Devices.....	4-70
Switches	4-71
Relays.....	4-71

Chapter 5

Engine Starting Systems

Introduction	5-1
Reciprocating Engine Starting Systems.....	5-1
Inertia Starters	5-1
Direct Cranking Electric Starter	5-2
Direct Cranking Electric Starting System for Large Reciprocating Engines.....	5-3
Direct Cranking Electric Starting System for Small Aircraft.....	5-6
Reciprocating Engine Starting System Maintenance Practices.....	5-6
Troubleshooting Small Aircraft Starting Systems.....	5-7
Gas Turbine Engine Starters.....	5-8
Electric Starting Systems & Starter Generator Starting System	5-10
Troubleshooting a Starter Generator Starting System.....	5-12
Air Turbine Starters	5-12
Air Turbine Starter Troubleshooting Guide	5-16

Chapter 6

Lubrication & Cooling Systems

Principles of Engine Lubrication.....	6-1
Types of Friction	6-1
Functions of Engine Oil.....	6-1
Requirements & Characteristics of Reciprocating Engine Lubricants.....	6-2
Viscosity.....	6-2
Viscosity Index.....	6-2
Flash Point & Fire Point.....	6-3
Cloud Point & Pour Point.....	6-3
Specific Gravity.....	6-3
Reciprocating Engine Lubrication Systems.....	6-4
Combination Splash & Pressure Lubrication	6-4
Lubrication System Requirements.....	6-4
Dry Sump Oil Systems.....	6-4
Oil Tanks	6-4
Oil Pump.....	6-6
Oil Filters.....	6-7
Oil Pressure Regulating Valve	6-7
Oil Pressure Gauge	6-8
Oil Temperature Indicator	6-9
Oil Cooler.....	6-9
Oil Cooler Flow Control Valve.....	6-9
Surge Protection Valves	6-10
Airflow Controls.....	6-10
Dry Sump Lubrication System Operation	6-11
Wet-Sump Lubrication System Operation	6-13
Lubrication System Maintenance Practices	6-13
Oil Tank.....	6-13

Oil Cooler	6-14
Oil Temperature Bulbs	6-15
Pressure & Scavenge Oil Screens	6-15
Oil Pressure Relief Valve	6-16
Recommendations for Changing Oil	6-17
Draining Oil	6-17
Oil & Filter Change & Screen Cleaning	6-17
Oil Filter Removal Canister Type Housing	6-17
Oil Filter/Screen Content Inspection	6-17
Assembly of & Installation of Oil Filters	6-18
Troubleshooting Oil Systems	6-18
Requirements for Turbine Engine Lubricants	6-18
Turbine Oil Health & Safety Precautions	6-19
Spectrometric Oil Analysis Program	6-20
Typical Wear Metals & Additives	6-20
Turbine Engine Lubrication Systems	6-20
Turbine Lubrication System Components	6-21
Oil Tank	6-21
Oil Pump	6-22
Turbine Oil Filters	6-23
Oil Pressure Regulating Valve	6-24
Oil Pressure Relief Valve	6-24
Oil Jets	6-25
Lubrication System Instrumentation	6-25
Lubrication System Breather Systems (Vents)	6-25
Lubrication System Check Valve	6-26
Lubrication System Thermostatic Bypass Valves	6-27
Air-Oil Coolers	6-27
Fuel-Oil Coolers	6-27
Deoiler	6-28
Magnetic Chip Detectors	6-28
Typical Dry-Sump Pressure Regulated Turbine Lubrication System	6-28
Pressure System	6-28
Scavenge System	6-28
Breather Pressurizing System	6-29
Typical Dry-Sump Variable Pressure Lubrication System	6-29
Pressure Subsystem	6-29
Scavenger Subsystem	6-30
Breather Subsystem	6-30
Turbine Engine Wet-Sump Lubrication System	6-30
Turbine Engine Oil System Maintenance	6-31
Engine Cooling Systems	6-32
Reciprocating Engine Cooling Systems	6-32
Reciprocating Engine Cooling System Maintenance	6-34
Maintenance of Engine Cowling	6-34
Engine Cylinder Cooling Fin Inspection	6-36
Cylinder Baffle & Deflector System Inspection	6-36
Cylinder Temperature Indicating Systems	6-37
Exhaust Gas Temperature Indicating Systems	6-38
Turbine Engine Cooling	6-38
Accessory Zone Cooling	6-38

Turbine Engine Insulation Blankets	6-40
--	------

Chapter 7

Propellers

General	7-1
Basic Propeller Principles	7-1
Propeller Aerodynamic Process	7-2
Aerodynamic Factors	7-4
Propeller Controls & Instruments	7-5
Propeller Location	7-5
Tractor Propeller	7-5
Pusher Propellers	7-6
Types of Propellers	7-6
Fixed-Pitch Propeller	7-6
Test Club Propeller	7-6
Ground-Adjustable Propeller	7-6
Controllable-Pitch Propeller	7-6
Constant-Speed Propellers	7-7
Feathering Propellers	7-8
Reverse-Pitch Propellers	7-8
Propeller Governor	7-8
Governor Mechanism	7-9
Underspeed Condition	7-9
Overspeed Condition	7-11
On-Speed Condition	7-11
Governor System Operation	7-11
Propellers Used on General Aviation Aircraft	7-12
Fixed-Pitch Wooden Propellers	7-12
Metal Fixed-Pitch Propellers	7-13
Constant-Speed Propellers	7-14
Hartzell Constant-Speed, Nonfeathering	7-14
Constant-Speed Feathering Propeller	7-15
Unfeathering	7-16
Propeller Auxiliary Systems	7-17
Ice Control Systems	7-17
Anti-Icing Systems	7-17
Deicing Systems	7-18
Propeller Synchronization & Synchrophasing	7-19
Autofeathering System	7-20
Propeller Inspection & Maintenance	7-20
Wood Propeller Inspection	7-21
Metal Propeller Inspection	7-21
Aluminum Propeller Inspection	7-21
Composite Propeller Inspection	7-21
Propeller Vibration	7-22
Blade Tracking	7-22
Checking & Adjusting Propeller Blade Angles	7-23
Universal Propeller Protractor	7-23
Propeller Balancing	7-24
Static Balancing	7-24
Dynamic Balancing	7-25

Balancing Procedure	7-25
Propeller Removal & Installation	7-26
Removal	7-26
Installation.....	7-27
Servicing Propellers	7-27
Cleaning Propeller Blades	7-27
Charging the Propeller Air Dome	7-27
Propeller Lubrication.....	7-27
Propeller Overhaul	7-29
The Hub	7-29
Prop Reassembly	7-29
Troubleshooting Propellers	7-30
Hunting & Surging.....	7-30
Engine Speed Varies with Flight Attitude (Airspeed)	7-30
Failure to Feather or Feathers Slowly	7-30
Turboprop Engines & Propeller Control Systems.....	7-30
Reduction Gear Assembly	7-31
Turbo-Propeller Assembly.....	7-31
Pratt & Whitney PT6 Hartzell Propeller System	7-31
Hamilton Standard Hydromatic Propellers	7-34
Principles of Operation	7-36
Feathering Operation.....	7-37
Unfeathering Operation	7-38
Setting the Propeller Governor	7-40

Chapter 8

Engine Removal & Replacement

Introduction	8-1
Reasons for Removal of Reciprocating Engines.....	8-1
Engine or Component Lifespan Exceeded	8-1
Engine Sudden Stoppage or Propeller Strike	8-1
Sudden Reduction in Speed	8-1
Metal Particles in the Oil	8-2
Spectrometric Oil Analysis Engine Inspection Program.....	8-2
Turbine Engine Condition Monitoring Programs	8-2
Engine Operational Problems.....	8-2
General Procedures for Engine Removal & Installation.....	8-3
Preparation of Engines for Installation.....	8-3
QECA Buildup Method for Changing of Engines	8-3
Depreservation of an Engine	8-4
Inspection & Depreservation of Accessories	8-5
Inspection & Replacement of Powerplant External Units & Systems.....	8-5
Preparing the Engine for Removal	8-6
Draining the Engine	8-6
Electrical Disconnects.....	8-6
Disconnection of Engine Controls.....	8-7
Disconnection of Lines.....	8-8
Other Disconnections	8-8
Removing the Engine	8-8
Hoisting the Engine.....	8-9
Hoisting & Mounting the Engine for Installation	8-9

Connections & Adjustments	8-10
Preparation of Engine for Ground & Flight Testing	8-12
Pre-Oiling	8-12
Fuel System Bleeding	8-13
Propeller Check	8-13
Checks & Adjustments After Engine Runup & Operation	8-13
Rigging, Inspections, & Adjustments	8-13
Rigging Power Controls	8-14
Adjusting the Fuel Control	8-14
Turboprop Powerplant Removal & Installation	8-15
Reciprocating Helicopter Engine & QECA	8-15
Removal of Helicopter QECA	8-16
Installation, Rigging, & Adjustment of Helicopter QECA	8-16
Testing the Engine Installation	8-16
Engine Mounts	8-16
Mounts for Reciprocating Engines	8-16
Mounts for Turbofan Engines	8-17
Turbine Vibration Isolation Engine Mounts	8-17
Preservation & Storage of Engines	8-18
Corrosion-Preventive Materials	8-18
Corrosion-Preventive Compounds	8-18
Dehydrating Agents	8-18
Engine Preservation & Return to Service	8-19
Engine Shipping Containers	8-21
Inspection of Stored Engines	8-21
Preservation & Depreservation of Gas Turbine Engines	8-22

Chapter 9

Engine Fire Protection Systems

Introduction	9-1
Components	9-1
Engine Fire Detection Systems	9-2
Thermal Switch System	9-2
Thermocouple Systems	9-2
Optical Fire Detection Systems	9-3
Pneumatic Thermal Fire Detection	9-3
Continuous-Loop Detector Systems	9-3
Fire Zones	9-7
Engine Fire Extinguishing System	9-7
Fire Extinguishing Agents	9-7
Turbine Engine Ground Fire Protection	9-8
Containers	9-8
Discharge Valves	9-8
Pressure Indication	9-8
Two-Way Check Valve	9-9
Discharge Indicators	9-9
Thermal Discharge Indicator (Red Disc)	9-9
Yellow Disc Discharge Indicator	9-9
Fire Switch	9-9
Warning Systems	9-10
Fire Detection System Maintenance	9-10

Fire Detection System Troubleshooting	9-11
Fire Extinguisher System Maintenance Practices	9-12
Boeing 777 Aircraft Fire Detection & Extinguishing System	9-13
Overheat Detection	9-13
Fire Detection	9-13
Nacelle Temperature Recording	9-13
Continuous Fault Monitoring	9-13
Single/Dual Loop Operation	9-14
System Test	9-14
Boeing 777 Fire Extinguisher System	9-14
Fire Extinguisher Containers	9-14
Squib	9-16
Engine Fire Switches	9-16
Engine Fire Operation	9-17
APU Fire Detection & Extinguishing System	9-17
APU Fire Warning	9-18
Fire Bottle Discharge	9-18

Chapter 10

Engine Maintenance & Operation

Reciprocating Engine Overhaul	10-1
Top Overhaul	10-1
Major Overhaul & Major Repairs	10-1
General Overhaul Procedures	10-1
Receiving Inspection	10-2
Disassembly	10-2
Inspection Process	10-2
Visual Inspection	10-3
Cylinder Head	10-4
Piston, Valve Train, & Piston Pin	10-5
Crankshaft & Connecting Rods	10-5
Cleaning	10-5
Degreasing	10-5
Removing Hard Carbon	10-5
Structural Inspection	10-6
Dye Penetrant Inspection	10-6
Eddy Current Inspection	10-7
Ultrasonic Inspection	10-7
Pulse-Echo	10-7
Through Transmission	10-7
Resonance	10-7
Magnetic Particle Inspection	10-7
X-ray	10-7
Dimensional Inspection	10-7
Cylinder Barrel	10-7
Rocker Arms & Shafts	10-8
Crankshaft	10-9
Checking Alignment	10-9
Repair & Replacement	10-10
Cylinder Assembly Reconditioning	10-11
Piston & Piston Pins	10-11

Valves & Valve Springs	10-11
Refacing Valve Seats	10-13
Valve Reconditioning	10-14
Valve Lapping & Leak Testing	10-17
Piston Repairs	10-17
Cylinder Grinding & Honing	10-17
Reassembly	10-19
Installation & Testing	10-19
Testing Reciprocating Engines	10-19
Test Cell Requirements	10-20
Engine Instruments	10-20
Carburetor Air Temperature (CAT) Indicator	10-21
Fuel Pressure Indicator	10-21
Oil Pressure Indicator	10-22
Oil Temperature Indicator	10-22
Fuel-Flow Meter	10-22
Manifold Pressure Indicator	10-23
Tachometer Indicator	10-23
Cylinder Head Temperature Indicator	10-23
Torquemeter	10-24
Warning Systems	10-24
Reciprocating Engine Operation	10-24
Engine Instruments	10-24
Engine Starting	10-25
Pre-Oiling	10-25
Hydraulic Lock	10-25
Engine Warm-Up	10-25
Ground Check	10-26
Fuel Pressure & Oil Pressure Check	10-27
Propeller Pitch Check	10-27
Power Check	10-27
Idle Speed & Idle Mixture Checks	10-28
Engine Stopping	10-28
Basic Engine Operating Principles	10-29
Combustion Process	10-29
Detonation	10-29
Pre-Ignition	10-30
Backfiring	10-30
Afterfiring	10-31
Factors Affecting Engine Operation	10-31
Compression	10-31
Fuel Metering	10-31
Idle Mixture	10-33
Induction Manifold	10-33
Operational Effect of Valve Clearance	10-33
Engine Troubleshooting	10-35
Valve Blow-By	10-39
Cylinder Compression Tests	10-39
Differential Pressure Tester	10-39
Cylinder Replacement	10-41
Cylinder Removal	10-41

Cylinder Installation	10-42
Cold Cylinder Check	10-43
Turbine Engine Maintenance	10-44
Compressor Section	10-45
Inspection & Cleaning	10-45
Causes of Blade Damage	10-45
Blending & Replacement	10-47
Combustion Section Inspection	10-47
Marking Materials for Combustion Section Parts	10-49
Inspection & Repair of Combustion Chambers	10-49
Fuel Nozzle & Support Assemblies	10-50
Turbine Disc Inspection	10-50
Turbine Blade Inspection	10-50
Turbine Blade Replacement Procedure	10-51
Turbine Nozzle Inlet Guide Vane Inspection	10-52
Clearances	10-52
Exhaust Section	10-54
Engine Ratings	10-54
Turbine Engine Instruments	10-54
Engine Pressure Ratio Indicator	10-54
Torquemeter (Turboprop Engines)	10-55
Tachometer	10-55
Exhaust Gas Temperature Indicator (EGT)	10-55
Fuel-Flow Indicator	10-55
Engine Oil Pressure Indicator	10-55
Engine Oil Temperature Indicator	10-55
Turbine Engine Operation	10-57
Ground Operation Engine Fire	10-57
Engine Checks	10-57
Checking Takeoff Thrust	10-57
Ambient Conditions	10-58
Engine Shutdown	10-58
Troubleshooting Turbine Engines	10-59
Turboprop Operation	10-59
Troubleshooting Procedures for Turboprop Engines	10-59
Turbine Engine Calibration & Testing	10-59
Turbine Engine Analyzer Uses	10-59
Analyzer Safety Precautions	10-61
Continuity Check of Aircraft EGT Circuit	10-63
Functional Check of Aircraft EGT Circuit	10-63
EGT Indicator Check	10-64
Resistance & Insulation Check	10-64
Tachometer Check	10-64
Troubleshooting EGT System	10-64
One or More Inoperative Thermocouples in Engine Parallel Harness	10-64
Engine Thermocouples Out of Calibration	10-64
EGT Circuit Error	10-65
Resistance of Circuit Out of Tolerance	10-65
Shorts to Ground/Shorts Between Leads	10-65
Troubleshooting Aircraft Tachometer System	10-65

Chapter 11

Light-Sport Aircraft Engines

Engine General Requirements	11-1
Personnel Authorized to Perform Inspection & Maintenance on Light-Sport Engines	11-2
Authorized Personnel That Meet FAA Regulations.....	11-3
Types of Light-Sport & Experimental Engines.....	11-3
Light-Sport Aircraft Engines	11-3
Two-Cycle, Two Cylinder Rotax Engine	11-3
Rotax 447 UL Single Capacitor Discharge Ignition (SCDI) & Rotax 503 UL Dual Capacitor Discharge Ignition (DCDI)	11-3
Rotax 582 UL DCDI	11-4
Description of Systems for Two-Stroke Engines.....	11-4
Cooling System of Rotax 447 UL SCDI & Rotax 503 UL DCDI	11-4
Cooling System of the Rotax 582 UL DCDI	11-4
Lubrication Systems	11-4
Oil Injection Lubrication of Rotax 503 UL DCDE & 582 UL DCDI	11-4
Electric System.....	11-5
Fuel System.....	11-5
Fuel-Oil Mixing Procedure	11-5
Opposed Light-Sport, Experimental, & Certificated Engines	11-5
Rotax 912/914	11-5
Description of Systems	11-6
Cooling System.....	11-6
Fuel System	11-6
Lubrication System	11-7
Electric System	11-8
Turbocharger & Control System	11-8
HKS 700T Engine	11-9
Jabiru Light-Sport Engines	11-10
Jabiru 2200 Aircraft Engine.....	11-11
Aeromax Aviation 100 (IFB) Aircraft Engine.....	11-11
Direct Drive VW Engines.....	11-12
Revmaster R-2300 Engine	11-12
Great Plains Aircraft Volkswagen (VW)Conversions	11-14
Teledyne Continental 0-200 Engine.....	11-15
Lycoming 0-233 Series Light-Sport Aircraft Engine	11-15
General Maintenance Practices on Light-Sport Rotax Engines	11-16
Maintenance Schedule Procedures & Maintenance Checklist.....	11-16
Carburetor Synchronization	11-17
Pneumatic Synchronization	11-18
Idle Speed Adjustment.....	11-19
Optimizing Engine Running	11-19
Checking the Carburetor Actuation.....	11-19
Lubrication System.....	11-19
Oil Level Check.....	11-19
Oil Change.....	11-20
Cleaning the Oil Tank.....	11-20
Inspecting the Magnetic Plug.....	11-21
Checking the Propeller Gearbox.....	11-21
Checking the Friction Torque in Free Rotation	11-21

Daily Maintenance Checks	11-21
Pre-flight Checks	11-22
Troubleshooting & Abnormal Operation	11-22
Troubleshooting	11-23
Engine Keeps Running With Ignition OFF	11-23
Knocking Under Load	11-23
Abnormal Operation.....	11-23
Exceeding the Maximum Admissible Engine Speed.....	11-23
Exceeding Maximum Admissible Cylinder Head Temperature	11-23
Exceeding Maximum Admissible Exhaust Gas Temperature.....	11-23
Engine Preservation	11-23
General Maintenance Practices for the Light-Sport Jabiru Engines	11-23
Engine & Engine Compartment Inspection.....	11-23
Lubrication System	11-24
Carburetor Adjustment & Checks	11-24
Spark Plugs	11-24
Exhaust System.....	11-24
Head Bolts	11-24
Tachometer & Sender	11-25
Engine Inspection Charts	11-25
Glossary	G-1
Index	I-1

Chapter 1

Aircraft Engines

General Requirements

Aircraft require thrust to produce enough speed for the wings to provide lift or enough thrust to overcome the weight of the aircraft for vertical takeoff. For an aircraft to remain in level flight, thrust must be provided that is equal to and in the opposite direction of the aircraft drag. This thrust, or propulsive force, is provided by a suitable type of aircraft heat engine. All heat engines have in common the ability to convert heat energy into mechanical energy by the flow of some fluid mass (generally air) through the engine. In all cases, the heat energy is released at a point in the cycle where the working pressure is high relative to atmospheric pressure.

The propulsive force is obtained by the displacement of a working fluid (again, atmospheric air). This air is not necessarily the same air used within the engine. By displacing air in a direction opposite to that in which the aircraft is propelled, thrust can be developed. This is an application of Newton's third law of motion. It states that for every action there is an equal and opposite reaction. So, as air is being displaced to the rear of the aircraft the aircraft is moved forward by this principle. One misinterpretation of this principle is air is pushing against the air behind the aircraft making it move forward. This is not true. Rockets in space have no air to push against, yet, they can produce thrust by using Newton's third law. Atmospheric air is the principal fluid used for propulsion in every type of aircraft powerplant except the rocket, in which the total combustion gases are accelerated and displaced. The rocket must provide all the fuel and oxygen for combustion and does not depend on atmospheric air. A rocket carries its own oxidizer rather than using ambient air for combustion. It discharges the gaseous byproducts of combustion through the exhaust nozzle at an extremely high velocity (action) and it is propelled in the other direction (reaction).

The propellers of aircraft powered by reciprocating or turboprop engines accelerate a large mass of air at a relatively lower velocity by turning a propeller. The same amount of thrust can be generated by accelerating a small mass of air to a very high velocity. The working fluid (air) used for the propulsive force is a different quantity of air than that used within the engine to produce the mechanical energy to turn the propeller.

Turbojets, ramjets, and pulse jets are examples of engines that accelerate a smaller quantity of air through a large velocity change. They use the same working fluid for propulsive force that is used within the engine. One problem with these types of engines is the noise made by the high velocity air exiting the engine. The term turbojet was used to describe any gas turbine engine, but with the differences in gas turbines used in aircraft, this term is used to describe a type of gas turbine that passes all the gases through the core of the engine directly.

Turbojets, ramjets, and pulse jets have very little to no use in modern aircraft due to noise and fuel consumption. Small general aviation aircraft use mostly horizontally opposed reciprocating piston engines. While some aircraft still use radial reciprocating piston engines, their use is very limited. Many aircraft use a form of the gas turbine engine to produce power for thrust. These engines are normally the turboprop, turboshaft, turbofan, and a few turbojet engines. "Turbojet" is the former term for any turbine engine. Now that there are so many different types of turbine engines, the term used to describe most turbine engines is "gas turbine engine." All four of the previously mentioned engines belong to the gas turbine family.

All aircraft engines must meet certain general requirements of efficiency, economy, and reliability. Besides being economical in fuel consumption, an aircraft engine must be economical in the cost of original procurement and the cost of maintenance; and it must meet exacting requirements of efficiency and low weight-to-horsepower ratio. It must be capable of sustained high-power output with no sacrifice in reliability; it must also have the durability to operate for long periods of time between overhauls. It needs to be as compact as possible yet have easy accessibility for maintenance. It is required to be as vibration free as possible and be able to cover a wide range of power output at various speeds and altitudes.

These requirements dictate the use of ignition systems that deliver the firing impulse to the spark plugs at the proper time in all kinds of weather and under other adverse conditions. Engine fuel delivery systems provide metered fuel at the correct proportion of air-fuel ingested by the engine regardless of the attitude, altitude, or type of weather in which the engine is operated. The engine needs a type of oil system

that delivers oil under the proper pressure to lubricate and cool all of the operating parts of the engine when it is running. Also, it must have a system of damping units to damp out the vibrations of the engine when it is operating.

Power & Weight

The useful output of all aircraft powerplants is thrust, the force which propels the aircraft. Since the reciprocating engine is rated in brake horsepower (bhp), the gas turbine engine is rated in thrust horsepower (thp):

$$\text{Thp} = \frac{\text{thrust} \times \text{aircraft speed (mph)}}{375 \text{ mile-pounds per hour}}$$

The value of 375 mile-pounds per hour is derived from the basic horsepower formula as follows:

$$\begin{aligned} 1 \text{ hp} &= 33,000 \text{ ft-lb per minute} \\ 33,000 \times 60 &= 1,980,000 \text{ ft-lb per hour} \\ \frac{1,980,000}{5,280 \text{ ft in a mile}} &= 375 \text{ mile-pounds per hour} \end{aligned}$$

One horsepower equals 33,000 ft-lb per minute or 375 mile-pounds per hour. Under static conditions, thrust is figured as equivalent to approximately 2.6 pounds per hour.

If a gas turbine is producing 4,000 pounds of thrust and the aircraft in which the engine is installed is traveling at 500 mph, the thp is:

$$\frac{4,000 \times 500}{375} = 5,333.33 \text{ thp}$$

It is necessary to calculate the horsepower for each speed of an aircraft, since the horsepower varies with speed. Therefore, it is not practical to try to rate or compare the output of a turbine engine on a horsepower basis. The aircraft engine operates at a relatively high percentage of its maximum power output throughout its service life. The aircraft engine is at full power output whenever a takeoff is made. It may hold this power for a period of time up to the limits set by the manufacturer. The engine is seldom held at a maximum power for more than 2 minutes, and usually not that long. Within a few seconds after lift-off, the power is reduced to a power that is used for climbing and that can be maintained for longer periods of time. After the aircraft has climbed to cruising altitude, the power of the engine(s) is further reduced to a cruise power

which can be maintained for the duration of the flight.

If the weight of an engine per brake horsepower (called the specific weight of the engine) is decreased, the useful load that an aircraft can carry and the performance of the aircraft obviously are increased. Every excess pound of weight carried by an aircraft engine reduces its performance. Tremendous improvement in reducing the weight of the aircraft engine through improved design and metallurgy has resulted in reciprocating engines with a much improved power-to-weight ratio (specific weight).

Fuel Economy

The basic parameter for describing the fuel economy of aircraft engines is usually specific fuel consumption. Specific fuel consumption for gas turbines is the fuel flow measured in (lb/hr) divided by thrust (lb), and for reciprocating engines the fuel flow (lb/hr) divided by brake horsepower. These are called thrust-specific fuel consumption and brake-specific fuel consumption, respectively. Equivalent specific fuel consumption is used for the turboprop engine and is the fuel flow in pounds per hour divided by a turboprop's equivalent shaft horsepower. Comparisons can be made between the various engines on a specific fuel consumption basis. At low speed, the reciprocating and turboprop engines have better economy than the pure turbojet or turbofan engines. However, at high speed, because of losses in propeller efficiency, the reciprocating or turboprop engine's efficiency becomes limited above 400 mph less than that of the turbofan.

Durability & Reliability

Durability and reliability are usually considered identical factors since it is difficult to mention one without including the other. Simply put, reliability is measured as the mean time between failures, while durability is measured as the mean time between overhauls.

More specifically, an aircraft engine is reliable when it can perform at the specified ratings in widely varying flight attitudes and in extreme weather conditions. Standards of powerplant reliability are agreed upon by the Federal Aviation Administration (FAA), the engine manufacturer, and the airframe manufacturer. The engine manufacturer ensures the reliability of the product by design, research, and testing. Close control of manufacturing and assembly procedures is maintained, and each engine is tested before it leaves the factory.

Durability is the amount of engine life obtained while maintaining the desired reliability. The fact that an engine has successfully completed its type or proof test indicates that it can be operated in a normal manner over a long period before requiring overhaul. However, no definite time interval between overhauls is specified or implied in the engine

rating. The time between overhauls (TBO) varies with the operating conditions, such as engine temperatures, amount of time the engine is operated at high-power settings, and the maintenance received. Recommended TBOs are specified by the engine manufacturer.

Reliability and durability are built into the engine by the manufacturer, but the continued reliability of the engine is determined by the maintenance, overhaul, and operating personnel. Careful maintenance and overhaul methods, thorough periodical and preflight inspections, and strict observance of the operating limits established by the engine manufacturer make engine failure a rare occurrence.

Operating Flexibility

Operating flexibility is the ability of an engine to run smoothly and give desired performance at all speeds from idling to full-power output. The aircraft engine must also function efficiently through all the variations in atmospheric conditions encountered in widespread operations.

Compactness

To affect proper streamlining and balancing of an aircraft, the shape and size of the engine must be as compact as possible. In single-engine aircraft, the shape and size of the engine also affect the view of the pilot, making a smaller engine better from this standpoint, in addition to reducing the drag created by a large frontal area.

Weight limitations, naturally, are closely related to the compactness requirement. The more elongated and spread out an engine is, the more difficult it becomes to keep the specific weight within the allowable limits.

Powerplant Selection

Engine specific weight and specific fuel consumption were discussed in the previous paragraphs, but for certain design requirements, the final powerplant selection may be based on factors other than those that can be discussed from an analytical point of view. For that reason, a general discussion of powerplant selection follows.

For aircraft whose cruising speed does not exceed 250 mph, the reciprocating engine is the usual choice of powerplant. When economy is required in the low speed range, the conventional reciprocating engine is chosen because of its excellent efficiency and relatively low cost. When high altitude performance is required, the turbo-supercharged reciprocating engine may be chosen because it is capable of maintaining rated power to a high altitude (above 30,000 feet). Gas turbine engines operate most economically at high altitudes. Although in most cases the gas turbine engine provides superior performance, the cost of gas turbine

engines is a limiting factor. In the range of cruising speed of 180 to 350 mph, the turboprop engine performs very well. It develops more power per pound of weight than does the reciprocating engine, thus allowing a greater fuel load or payload for engines of a given power. From 350 mph up to Mach .8–.9, turbofan engines are generally used for airline operations. Aircraft intended to operate at Mach 1 or higher are powered by pure turbojet engines/afterburning (augmented) engines, or low-bypass turbofan engines.

Types of Engines

Aircraft engines can be classified by several methods. They can be classed by operating cycles, cylinder arrangement, or the method of thrust production. All are heat engines that convert fuel into heat energy that is converted to mechanical energy to produce thrust. Most of the current aircraft engines are of the internal combustion type because the combustion process takes place inside the engine. Aircraft engines come in many different types, such as gas turbine based, reciprocating piston, rotary, two or four cycle, spark ignition, diesel, and air or water cooled. Reciprocating and gas turbine engines also have subdivisions based on the type of cylinder arrangement (piston) and speed range (gas turbine).

Many types of reciprocating engines have been designed. However, manufacturers have developed some designs that are used more commonly than others and are, therefore, recognized as conventional. Reciprocating engines may be classified according to the cylinder arrangement (inline, V-type, radial, and opposed) or according to the method of cooling (liquid cooled or air cooled). Actually, all piston engines are cooled by transferring excess heat to the surrounding air. In air-cooled engines, this heat transfer is direct from the cylinders to the air. Therefore, it is necessary to provide thin metal fins on the cylinders of an air-cooled engine in order to have increased surface for sufficient heat transfer. Most reciprocating aircraft engines are air cooled although a few high powered engines use an efficient liquid-cooling system. In liquid-cooled engines, the heat is transferred from the cylinders to the coolant, which is then sent through tubing and cooled within a radiator placed in the airstream. The coolant radiator must be large enough to cool the liquid efficiently. The main problem with liquid cooling is the added weight of coolant, heat exchanger (radiator), and tubing to connect the components. Liquid cooled engines do allow high power to be obtained from the engine safely.

Inline Engines

An inline engine generally has an even number of cylinders, although some three-cylinder engines have been constructed. This engine may be either liquid cooled or air cooled and has only one crank shaft, which is located either above or below the cylinders. If the engine is designed to operate with the

cylinders below the crankshaft, it is called an inverted engine.

The inline engine has a small frontal area and is better adapted to streamlining. When mounted with the cylinders in an inverted position, it offers the added advantages of a shorter landing gear and greater pilot visibility. With increase in engine size, the air cooled, inline type offers additional problems to provide proper cooling; therefore, this type of engine is confined to low- and medium-horsepower engines used in very old light aircraft.

Opposed or O-Type Engines

The opposed-type engine has two banks of cylinders directly opposite each other with a crankshaft in the center. [Figure 1-1] The pistons of both cylinder banks are connected to the single crankshaft. Although the engine can be either liquid cooled or air cooled, the air-cooled version is used predominantly in aviation. It is generally mounted with the cylinders in a horizontal position. The opposed-type engine has a low weight-to-horsepower ratio, and its narrow silhouette makes it ideal for horizontal installation on the aircraft wings (twin engine applications). Another advantage is its low vibration characteristics.

V-Type Engines

In V-type engines, the cylinders are arranged in two inline banks generally set 60° apart. Most of the engines have 12 cylinders, which are either liquid cooled or air cooled. The engines are designated by a V followed by a dash and the piston displacement in cubic inches. For example, V-1710. This type of engine was used mostly during the Second World War and its use is mostly limited to older aircraft.

Radial Engines

The radial engine consists of a row, or rows, of cylinders arranged radially about a central crankcase. [Figure 1-2] This type of engine has proven to be very rugged and dependable. The number of cylinders which make up a row may be three,



Figure 1-2. Radial engine.

five, seven, or nine. Some radial engines have two rows of seven or nine cylinders arranged radially about the crankcase, one in front of the other. These are called double-row radials. [Figure 1-3] One type of radial engine has four rows of cylinders with seven cylinders in each row for a total of 28 cylinders. Radial engines are still used in some older cargo airplanes, war birds, and crop spray airplanes. Although many of these engines still exist, their use is limited. The single-row, nine-cylinder radial engine is of relatively simple construction, having a one-piece nose and a two-section main crankcase. The larger twin-row engines are of slightly more complex construction than the single row engines. For example, the crankcase of the Wright R-3350 engine is composed of the crankcase front section, four crankcase main sections (front main, front center, rear center, and



Figure 1-1. A typical four-cylinder opposed engine.



Figure 1-3. Double row radials.

rear main), rear cam and tappet housing, supercharger front housing, supercharger rear housing, and supercharger rear housing cover. Pratt and Whitney engines of comparable size incorporate the same basic sections, although the construction and the nomenclature differ considerably.

Reciprocating Engines

Design & Construction

The basic major components of a reciprocating engine are the crankcase, cylinders, pistons, connecting rods, valves, valve-operating mechanism, and crankshaft. In the head of each cylinder are the valves and spark plugs. One of the valves is in a passage leading from the induction system; the other is in a passage leading to the exhaust system. Inside each cylinder is a movable piston connected to a crankshaft by a connecting rod. *Figure 1-4* illustrates the basic parts of a reciprocating engine.

Crankcase Section

The foundation of an engine is the crankcase. It contains the bearings and bearing supports in which the crankshaft revolves. Besides supporting itself, the crankcase must provide a tight enclosure for the lubricating oil and must support various external and internal mechanisms of the

engine. It also provides support for attachment of the cylinder assemblies, and the powerplant to the aircraft. It must be sufficiently rigid and strong to prevent misalignment of the crankshaft and its bearings. Cast or forged aluminum alloy is generally used for crankcase construction because it is light and strong. The crankcase is subjected to many variations of mechanical loads and other forces. Since the cylinders are fastened to the crankcase, the tremendous forces placed on the cylinder tend to pull the cylinder off the crankcase. The unbalanced centrifugal and inertia forces of the crankshaft acting through the main bearings subject the crankcase to bending moments which change continuously in direction and magnitude. The crankcase must have sufficient stiffness to withstand these bending moments without major deflections. [*Figure 1-5*]

If the engine is equipped with a propeller reduction gear, the front or drive end is subjected to additional forces. In addition to the thrust forces developed by the propeller under high power output, there are severe centrifugal and gyroscopic forces applied to the crankcase due to sudden changes in the direction of flight, such as those occurring during maneuvers of the airplane. Gyroscopic forces are particularly severe when a heavy propeller is installed. To absorb centrifugal loads, a large centrifugal bearing is used in the nose section.

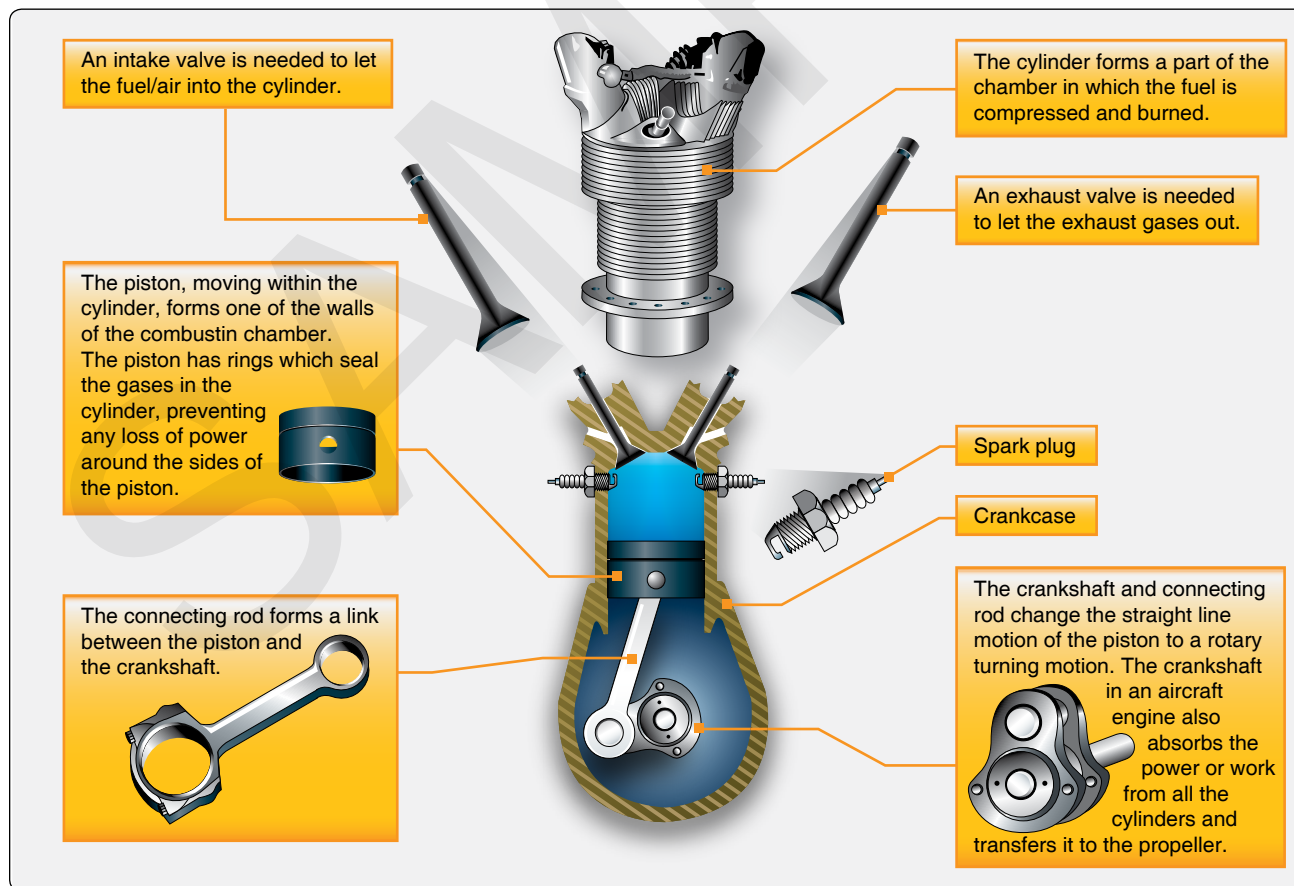

Figure 1-4. Basic parts of a reciprocating engine.



Figure 1-5. *The crankcase.*

The shape of the nose or front of the crankcase section varies considerably. In general, it is either tapered or round. Depending upon the type of reciprocating engine, the nose or front area of the crankcase varies somewhat. If the propeller is driven directly by the crankshaft, less area is needed for this component of the engine. The crankcases used on engines having opposed or inline cylinder arrangements vary in form for the different types of engines, but in general they are approximately cylindrical. One or more sides are surfaced to serve as a base to which the cylinders are attached by means of cap screws, bolts, or studs. These accurately machined surfaces are frequently referred to as cylinder pads.

If the propeller is driven by reduction gearing (gears that slow down the speed of the propeller less than the engine), more area is required to house the reduction gears. A tapered nose section is used quite frequently on direct-drive, low-powered engines, because extra space is not required to house the propeller reduction gears. Crankcase nose sections are usually cast of either aluminum alloy or magnesium. The crankcase nose section on engines that develop from 1,000 to 2,500 hp is usually larger to house reduction gears and sometimes ribbed to get as much strength as possible.

The governor is used to control propeller speed and blade angle. The mounting of the propeller governor varies. On some engines, it is located on the rear section, although this complicates the installation, especially if the propeller is operated or controlled by oil pressure, because of the distance between the governor and propeller. Where hydraulically operated propellers are used, it is good practice to mount the governor on the nose section as close to the propeller as possible to reduce the length of the oil passages. The governor is then driven either from gear teeth on the periphery of the bell gear or by some other suitable means. This basic

arrangement is also used for turboprops.

On some of the larger radial engines, a small chamber is located on the bottom of the nose section to collect the oil. This is called the nose section oil sump. Since the nose section transmits many varied forces to the main crankcase or power section, it must be secured properly to transmit the loads efficiently.

The machined surfaces on which the cylinders are mounted are called cylinder pads. They are provided with a suitable means of retaining or fastening the cylinders to the crankcase. The general practice in securing the cylinder flange to the pad is to mount studs in threaded holes in the crankcase. The inner portion of the cylinder pads are sometimes chamfered or tapered to permit the installation of a large rubber O-ring around the cylinder skirt, which effectively seals the joint between the cylinder and the crankcase pads against oil leakage.

Because oil is thrown about the crankcase, especially on inverted inline and radial-type engines, the cylinder skirts extend a considerable distance into the crankcase sections to reduce the flow of oil into the inverted cylinders. The piston and ring assemblies must be arranged so that they throw out the oil splashed directly into them.

Mounting lugs are spaced about the periphery of the rear of the crankcase or the diffuser section of a radial engine. These are used to attach the engine assembly to the engine mount or framework provided for attaching the powerplant to the fuselage of single-engine aircraft or to the wing nacelle structure of multiengine aircraft. The mounting lugs may be either integral with the crankcase or diffuser section or detachable, as in the case of flexible or dynamic engine mounts.

The mounting arrangement supports the entire powerplant including the propeller, and therefore is designed to provide ample strength for rapid maneuvers or other loadings. Because of the elongation and contraction of the cylinders, the intake pipes which carry the mixture from the diffuser chamber through the intake valve ports are arranged to provide a slip joint which must be leak proof. The atmospheric pressure on the outside of the case of an un-supercharged engine is higher than on the inside, especially when the engine is operating at idling speed. If the engine is equipped with a supercharger and operated at full throttle, the pressure is considerably higher on the inside than on the outside of the case. If the slip joint connection has a slight leakage, the engine may idle fast due to a slight leaning of the mixture. If the leak is quite large, it may not idle at all. At open throttle, a small leak probably would not be noticeable in operation of the engine, but the slight leaning of the air-fuel mixture might cause detonation or damage to the valves and valve seats. On some radial engines, the intake pipe has considerable length

and on some inline engines, the intake pipe is at right angles to the cylinders. In these cases, flexibility of the intake pipe or its arrangement eliminates the need for a slip joint. In any case, the engine induction system must be arranged so that it does not leak air and change the desired air-fuel ratio.

Accessory Section

The accessory (rear) section usually is of cast construction and the material may be either aluminum alloy, which is used most widely, or magnesium, which has been used to some extent. On some engines, it is cast in one piece and provided with means for mounting the accessories, such as magnetos, carburetors, fuel, oil, vacuum pumps, starter, generator, tachometer drive, etc., in the various locations required to facilitate accessibility. Other adaptations consist of an aluminum alloy casting and a separate cast magnesium cover plate on which the accessory mounts are arranged. Accessory drive shafts are mounted in suitable drive arrangements that are carried out to the accessory mounting pads. In this manner, the various gear ratios can be arranged to give the proper drive speed to magnetos, pumps, and other accessories to obtain correct timing or functioning.

Accessory Gear Trains

Gear trains, containing both spur- and bevel-type gears, are used in the different types of engines for driving engine components and accessories. Spur-type gears are generally used to drive the heavier loaded accessories or those requiring the least play or backlash in the gear train. Bevel gears permit angular location of short stub shafts leading to the various accessory mounting pads. On opposed, reciprocating engines, the accessory gear trains are usually simple arrangements. Many of these engines use simple gear trains to drive the engine's accessories at the proper speeds.

Crankshafts

The crankshaft is carried in a position parallel to the longitudinal axis of the crankcase and is generally supported by a main bearing between each throw. The crankshaft main bearings must be supported rigidly in the crankcase. This usually is accomplished by means of transverse webs in the crankcase, one for each main bearing. The webs form an integral part of the structure and, in addition to supporting the main bearings, add to the strength of the entire case.

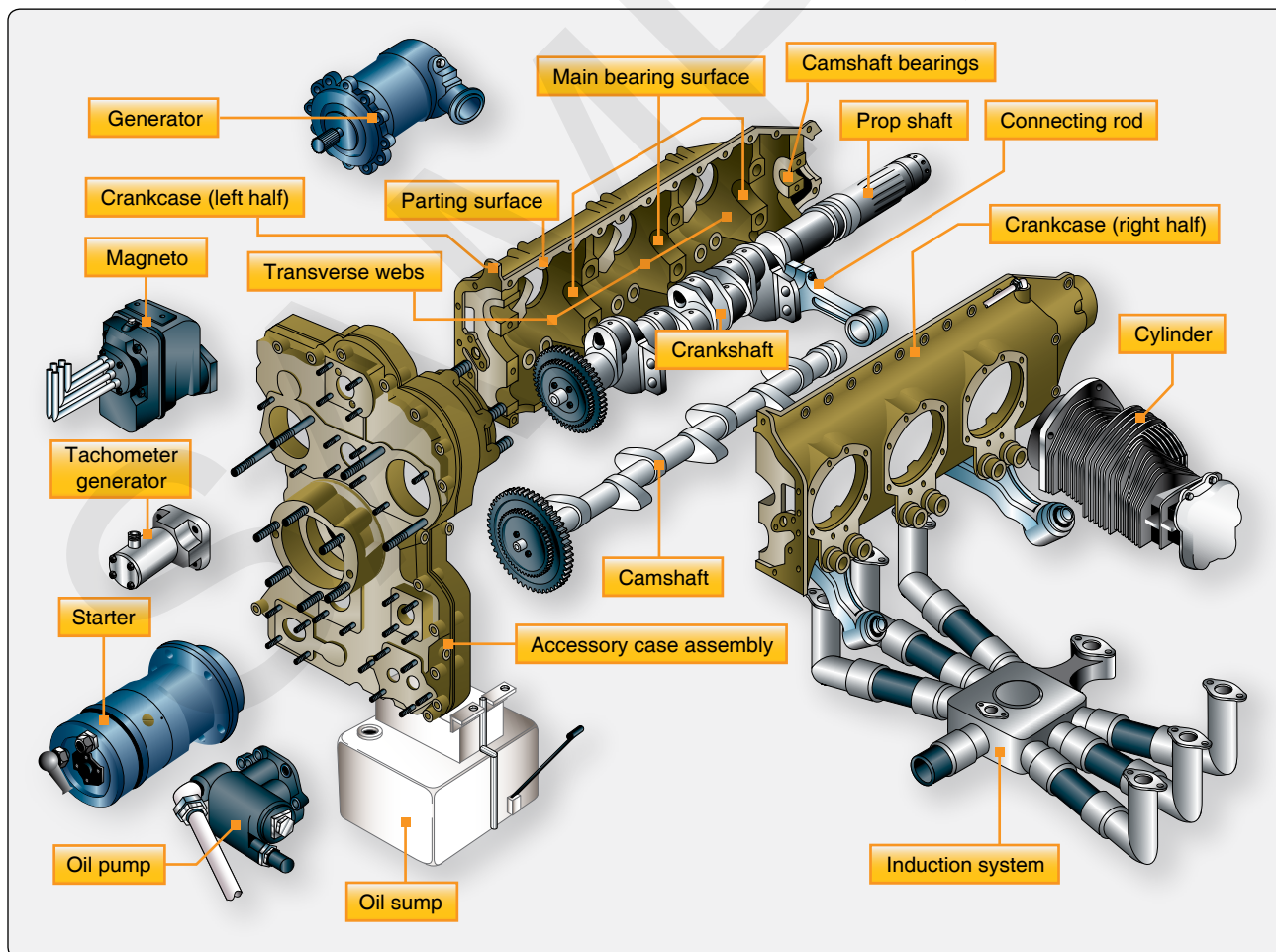

Figure 1-6. Typical opposed engine exploded into component assemblies.

The crankcase is divided into two sections in a longitudinal plane. This division may be in the plane of the crankshaft so that one-half of the main bearing (and sometimes camshaft bearings) are carried in one section of the case and the other half in the opposite section. [Figure 1-6] Another method is to divide the case in such a manner that the main bearings are secured to only one section of the case on which the cylinders are attached, thereby providing means of removing a section of the crankcase for inspection without disturbing the bearing adjustment.

The crankshaft is the backbone of the reciprocating engine. It is subjected to most of the forces developed by the engine. Its main purpose is to transform the reciprocating motion of the piston and connecting rod into rotary motion for rotation of the propeller. The crankshaft, as the name implies, is a shaft composed of one or more cranks located at specified points along its length. The cranks, or throws, are formed by forging offsets into a shaft before it is machined. Since crankshafts must be very strong, they generally are forged from a very strong alloy, such as chromium-nickel-molybdenum steel.

A crankshaft may be of single-piece or multipiece construction. Figure 1-7 shows two representative types of solid crankshafts used in aircraft engines. The four-throw construction may be used either on four-cylinder horizontal opposed or four-cylinder inline engines. The six-throw shaft is used on six-cylinder inline engines, 12-cylinder V-type engines, and six-cylinder opposed engines. Crankshafts of radial engines may be the single-throw, two-throw, or four-throw type, depending on whether the engine is the single-row, twin-row, or four-row type. A single-throw radial engine crankshaft is shown in Figure 1-8. No matter how many throws it may have, each crankshaft has three main parts—a journal, crankpin, and crank cheek. Flyweights and dampers, although not a true part of a crankshaft, are usually attached to it to reduce engine vibration.

The journal is supported by, and rotates in, a main bearing. It serves as the center of rotation of the crankshaft. It is surface-hardened to reduce wear. The crankpin is the section to which the connecting rod is attached. It is off-center from the main journals and is often called the throw. Two crank cheeks and a crankpin make a throw. When a force is applied to the crankpin in any direction other than parallel or perpendicular to and through the center line of the crankshaft, it causes the crankshaft to rotate. The outer surface is hardened by nitriding to increase its resistance to wear and to provide the required bearing surface. The crankpin is usually hollow. This reduces the total weight of the crankshaft and provides a passage for the transfer of lubricating oil. On early engines, the hollow crankpin also served as a chamber for collecting sludge, carbon deposits, and other foreign material. Centrifugal force

threw these substances to the outside of the chamber and kept them from reaching the connecting-rod bearing surface. Due to the use of ashless dispersant oils, newer engines no longer use sludge chambers. On some engines, a passage is drilled in the crank cheek to allow oil from the hollow crankshaft to be sprayed on the cylinder walls. The crank cheek connects the crankpin to the main journal. In some designs, the cheek extends beyond the journal and carries a flyweight to balance the crankshaft. The crank cheek must be of sturdy construction to obtain the required rigidity between the crankpin and the journal.

In all cases, the type of crankshaft and the number of crankpins must correspond with the cylinder arrangement of the engine. The position of the cranks on the crankshaft in relation to the other cranks of the same shaft is expressed in degrees.

The simplest crankshaft is the single-throw or 360° type. This type is used in a single-row radial engine. It can be constructed in one or two pieces. Two main bearings (one on each end) are provided when this type of crankshaft is used. The double-throw or 180° crankshaft is used on double-row radial engines. In the radial-type engine, one throw is provided for each row of cylinders.

Crankshaft Balance

Excessive vibration in an engine not only results in fatigue failure of the metal structures, but also causes the moving parts to wear rapidly. In some instances, excessive vibration is caused by a crankshaft that is not balanced. Crankshafts are balanced for static balance and dynamic balance. A crankshaft is statically balanced when the weight of the entire assembly of crankpins, crank cheeks, and flyweights is balanced around the axis of rotation. When checked for static balance, it is placed on two knife edges. If the shaft tends to turn toward any one position during the test, it is out of static balance. Any engine to be overhauled completely should receive a runout check of its crankshaft as a first step. Any question concerning crankshaft replacement is resolved at this time since a shaft whose runout is beyond limits must be replaced.

Dynamic Dampers

A crankshaft is dynamically balanced when all the forces created by crankshaft rotation and power impulses are balanced within themselves so that little or no vibration is produced when the engine is operating. To reduce vibration to a minimum during engine operation, dynamic dampers are incorporated on the crankshaft. A dynamic damper is merely a pendulum that is fastened to the crankshaft so that it is free to move in a small arc. It is incorporated in the flyweight assembly. Some crankshafts incorporate two or more of these assemblies, each being attached to a different crank cheek. The distance the pendulum moves and, thus, its vibrating

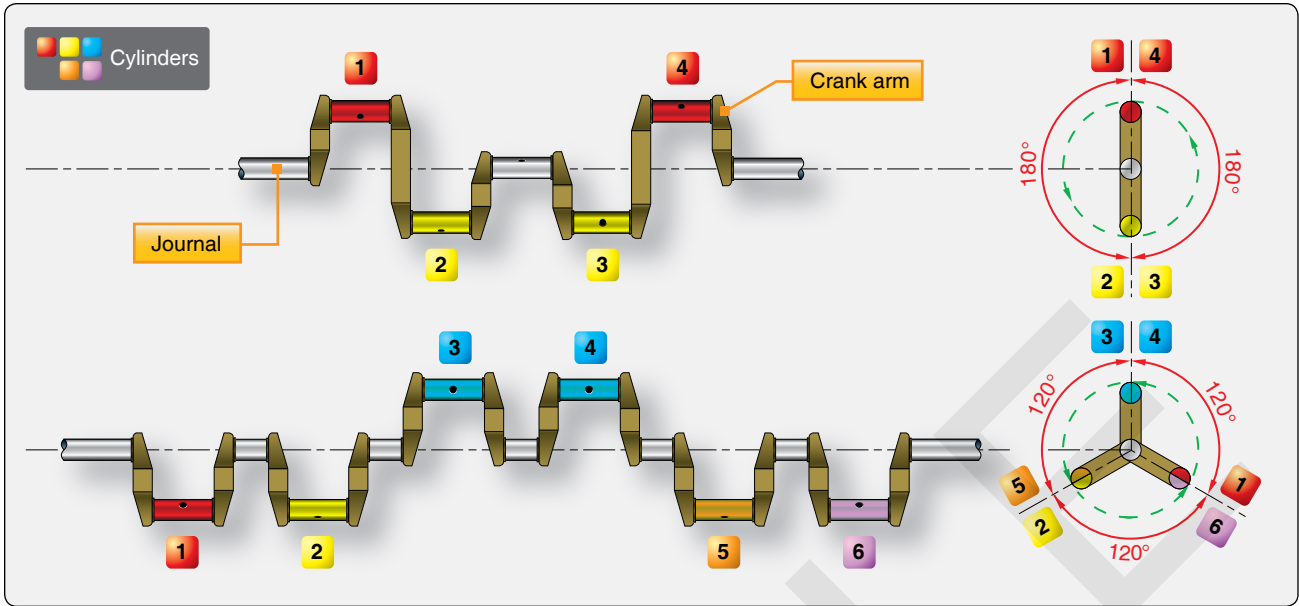

Figure 1-7. Solid types of crankshafts.

frequency corresponds to the frequency of the power impulses of the engine. When the vibration frequency of the crankshaft occurs, the pendulum oscillates out of time with the crankshaft vibration, thus reducing vibration to a minimum.

The construction of the dynamic damper used in one engine consists of a movable slotted-steel flyweight attached to the

crank cheek. Two spool-shaped steel pins extend into the slot and pass through oversized holes in the flyweight and crank cheek. The difference in the diameter between the pins and the holes provides a pendulum effect. An analogy of the functioning of a dynamic damper is shown in Figure 1-9.

Connecting Rods

The connecting rod is the link that transmits forces between the piston and the crankshaft. [Figure 1-10] Connecting rods must be strong enough to remain rigid under load and yet be light enough to reduce the inertia forces that are produced when the rod and piston stop, change direction, and start again at the end of each stroke.

There are four types of connecting-rod assemblies [Figure 1-11]:

1. Plain.
2. Fork and blade.
3. Master and articulated.
4. Split-type.

Master-and-Articulated Rod Assembly

The master-and-articulated rod assembly is commonly used in radial engines. In a radial engine, the piston in one cylinder in each row is connected to the crankshaft by a master rod. All other pistons in the row are connected to the master rod by articulated rods. In an 18-cylinder engine, which has two rows of cylinders, there are two master rods and 16 articulated rods. The articulated rods are constructed of forged steel alloy in either the I- or H-shape, denoting the cross-sectional shape. Bronze bushings are pressed into the

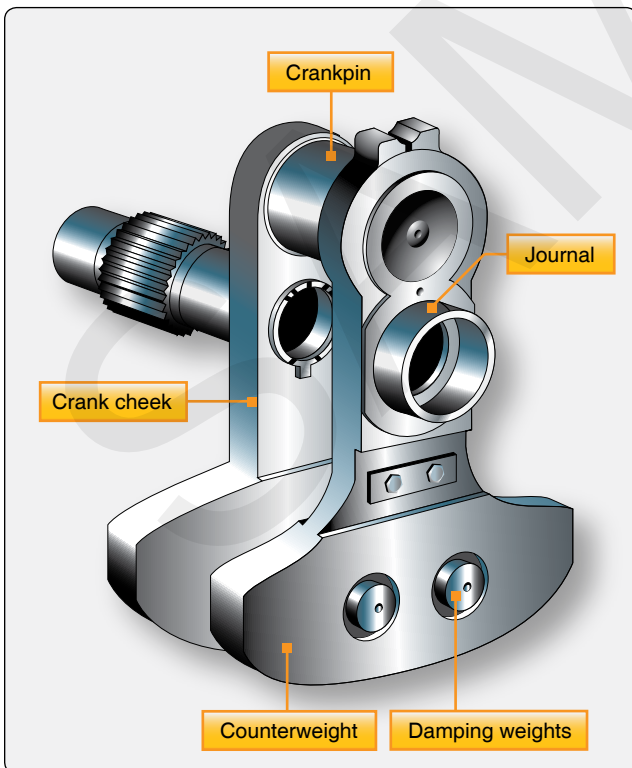

Figure 1-8. A single-throw radial engine crankshaft.

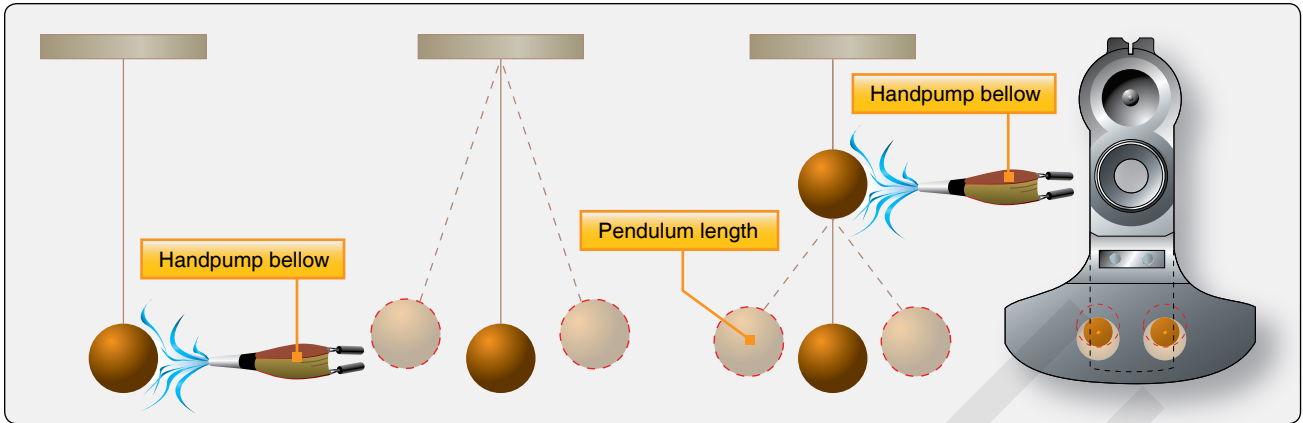

Figure 1-9. Principles of a dynamic damper.

bores in each end of the articulated rod to provide knuckle-pin and piston-pin bearings.

The master rod serves as the connecting link between the piston pin and the crankpin. The crankpin end, or the big end, contains the crankpin or master rod bearing. Flanges around the big end provide for the attachment of the articulated rods. The articulated rods are attached to the master rod by knuckle pins, which are pressed into holes in the master rod flanges during assembly. A plain bearing, usually called a piston-pin bushing, is installed in the piston end of the master rod to receive the piston pin.

When a crankshaft of the split-spline or split-clamp type is employed, a one-piece master rod is used. The master and articulated rods are assembled and then installed on the crankpin; the crankshaft sections are then joined together. In engines that use the one-piece type of crankshaft, the big end of the master rod is split, as is the master rod bearing. The main part of the master rod is installed on the crankpin; then the bearing cap is set in place and bolted to the master rod. The centers of the knuckle pins do not coincide with the center of the crankpin. Thus, while the crankpin center describes a true circle for each revolution of the crankshaft, the centers of the knuckle pins describe an elliptical path. [Figure 1-12] The elliptical paths are symmetrical about a center line through the master rod cylinder. It can be seen that the major diameters of the ellipses are not the same. Thus, the link rods have varying degrees of angularity relative to the center of the crank throw.

Because of the varying angularity of the link rods and the elliptical motion of the knuckle pins, all pistons do not move an equal amount in each cylinder for a given number of degrees of crank throw movement. This variation in piston position between cylinders can have considerable effect on engine operation. To minimize the effect of these factors on valve and ignition timing, the knuckle pin holes in the master rod flange are not equidistant from the center of the crankpin, thereby

offsetting to an extent the effect of the link rod angularity.

Another method of minimizing the adverse effects on engine operation is to use a compensated magneto. In this magneto the breaker cam has a number of lobes equal to the number of cylinders on the engine. To compensate for the variation in piston position due to link rod angularity, the breaker cam lobes are ground with uneven spacing. This allows the breaker contacts to open when the piston is in the correct firing position. This is further outlined during the discussion on ignition timing in Chapter 4, Engine Ignition & Electrical Systems.

Knuckle Pins

The knuckle pins are of solid construction except for the oil passages drilled in the pins, which lubricate the knuckle pin bushings. These pins may be installed by pressing into holes in the master rod flanges so that they are prevented from turning in the master rod. Knuckle pins may also be installed with a loose fit so that they can turn in the master rod flange holes, and also turn in the articulating rod bushings. These are called full-floating knuckle pins. In either type of installation, a lock plate on each side retains the knuckle pin and prevents a lateral movement.

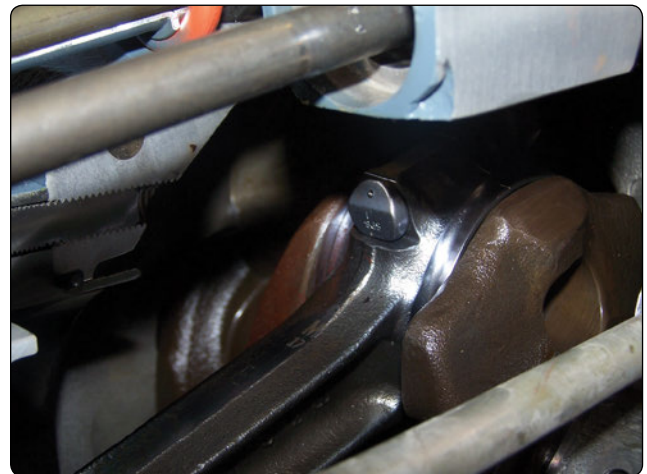

Figure 1-10. A connecting rod between the piston and crankshaft.

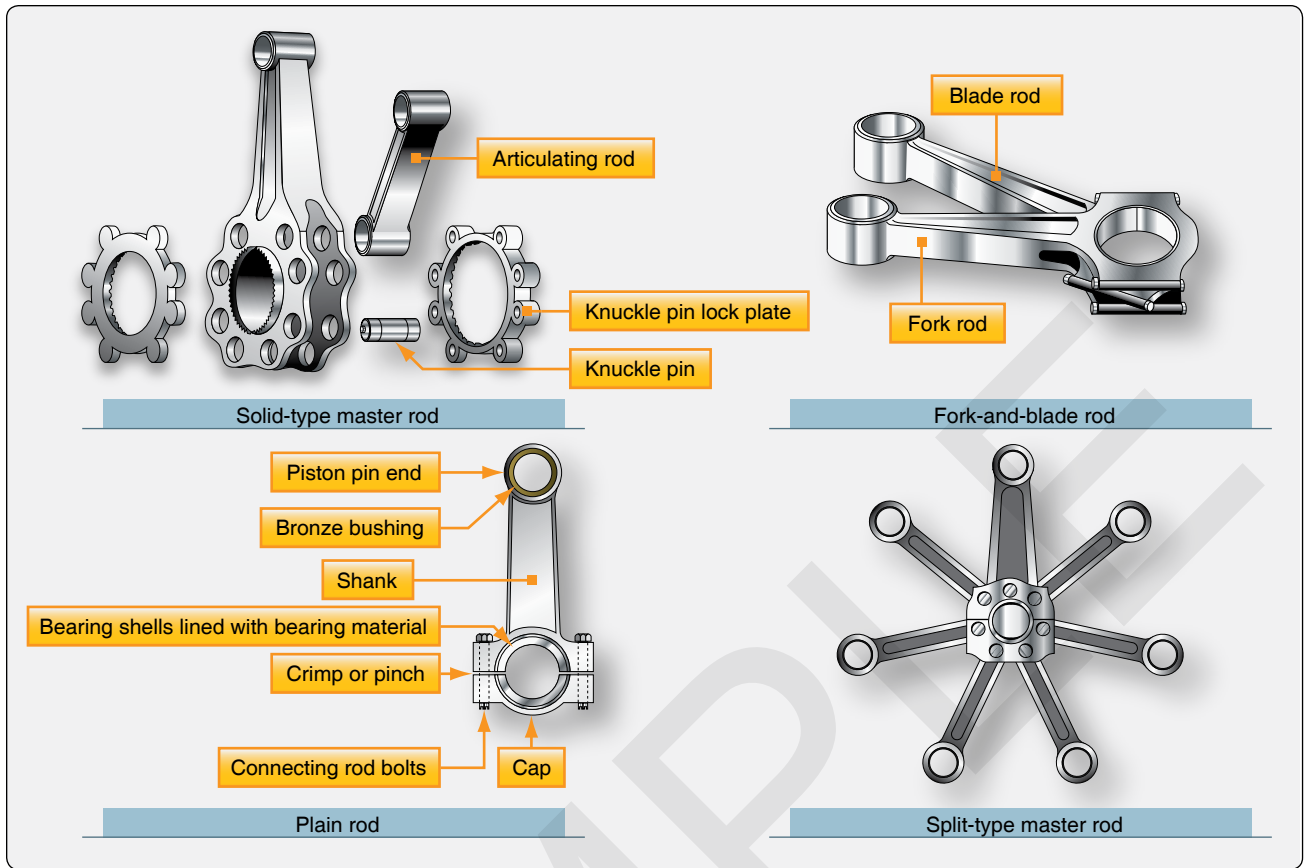

Figure 1-11. Connecting rod assemblies.

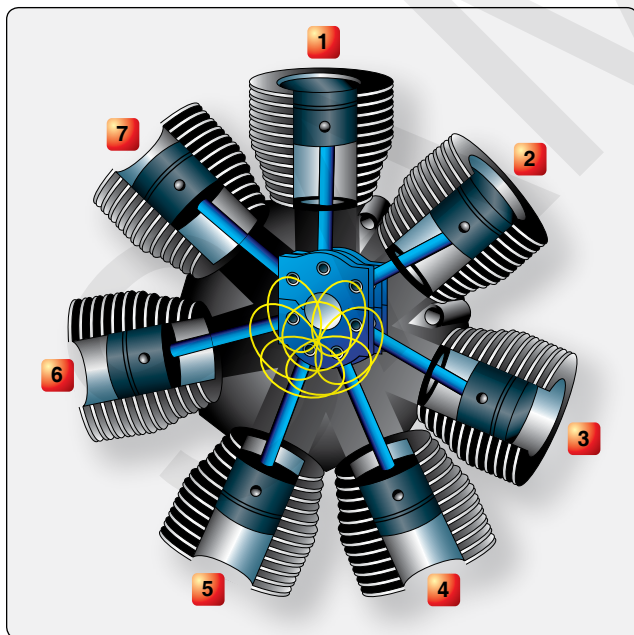

Figure 1-12. Elliptical travel path of knuckle pins in an articulated rod assembly.

Plain-Type Connecting Rods

Plain-type connecting rods are used in inline and opposed engines. The end of the rod attached to the crankpin is fitted with a cap and a two-piece bearing. The bearing cap is held on the end of the rod by bolts or studs. To maintain proper fit and balance, connecting rods should always be replaced in the same cylinder and in the same relative position.

Fork-and-Blade Rod Assembly

The fork-and-blade rod assembly is used primarily in V-type engines. The forked rod is split at the crankpin end to allow space for the blade rod to fit between the prongs. A single two-piece bearing is used on the crankshaft end of the rod. This type of connecting rod is not used much on modern engines.

Pistons

The piston of a reciprocating engine is a cylindrical member which moves back and forth within a steel cylinder. [Figure 1-13] The piston acts as a moving wall within the combustion chamber. As the piston moves down in the cylinder, it draws in the air-fuel mixture. As it moves upward, it compresses the charge, ignition occurs, and the expanding gases force the piston downward. This force is transmitted to the crankshaft through the connecting rod. On the return upward stroke, the piston forces the exhaust gases from the cylinder and the cycle repeats.



Figure 1-13. A piston.

Piston Construction

The majority of aircraft engine pistons are machined from aluminum alloy forgings. Grooves are machined in the outside surface of the piston to receive the piston rings, and cooling fins are provided on the inside of the piston for greater heat transfer to the engine oil.

Pistons may be either the trunk type or the slipper type. [Figure 1-14] Slipper-type pistons are not used in modern, high-powered engines because they do not provide adequate

strength or wear resistance. The top of the piston, or head, may be flat, convex, or concave. Recesses may be machined in the piston head to prevent interference with the valves.

Modern engines use cam ground pistons that are a larger diameter perpendicular to the piston pin. This larger diameter keeps the piston straight in the cylinder as the engine warms up from initial startup. As the piston heats up during warm up, the part of the piston in line with the pin has more mass and expands more making the piston completely round. At low temperatures, the piston is oval shaped and, when it warms to operating temperature, it becomes round. This process reduces the tendency of the piston to cock or slap in the cylinder during warm up. When the engine reaches its normal operating temperature, the piston assumes the correct dimensions in the cylinder.

As many as six grooves may be machined around the piston to accommodate the compression rings and oil rings. [Figure 1-15] The compression rings are installed in the three uppermost grooves; the oil control rings are installed immediately above the piston pin. The piston is usually drilled at the oil control ring grooves to allow surplus oil scraped from the cylinder walls by the oil control rings to pass back into the crankcase. An oil scraper ring is installed at the base of the piston wall or skirt to prevent excessive oil consumption. The portions of the piston walls that lie between

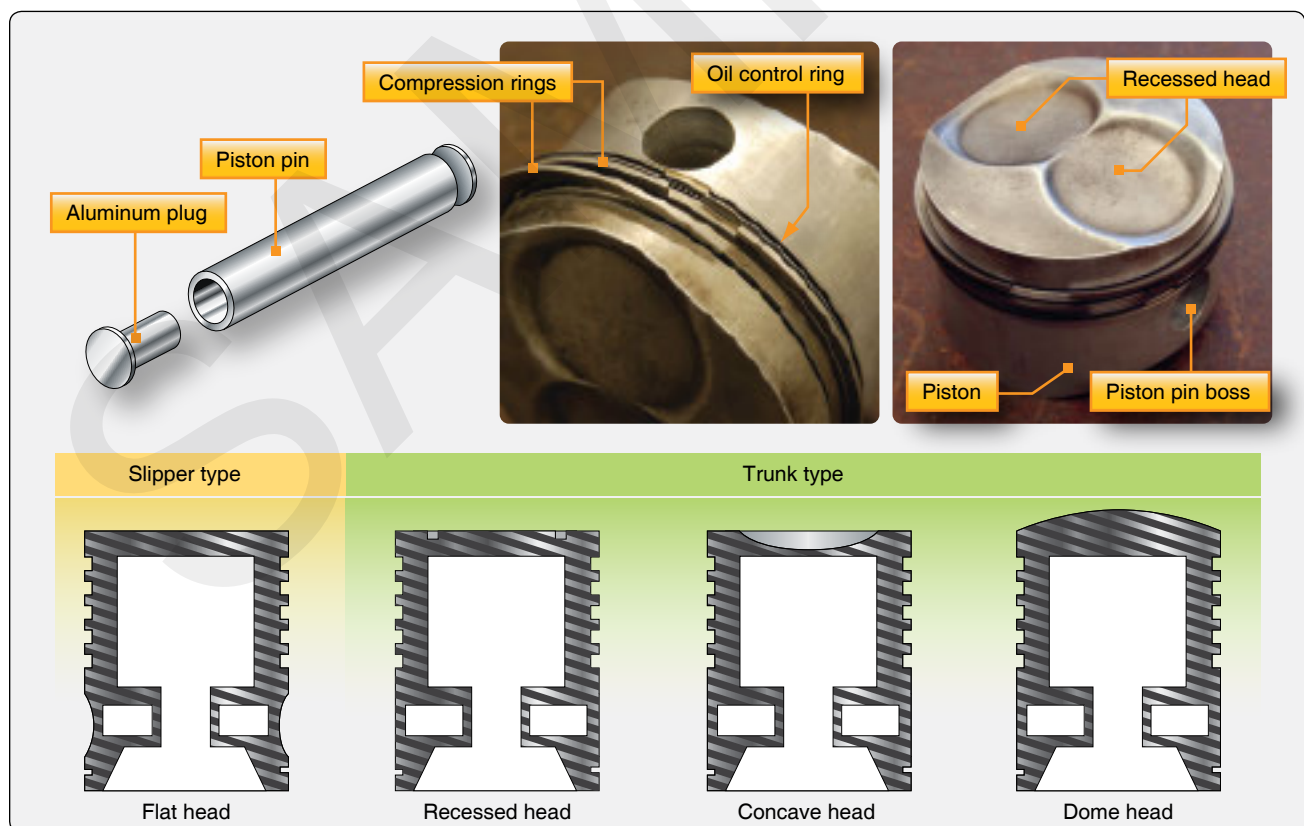

Figure 1-14. Piston assembly and types of pistons.

ring grooves are called the ring lands. In addition to acting as a guide for the piston head, the piston skirt incorporates the piston-pin bosses. The piston-pin bosses are of heavy construction to enable the heavy load on the piston head to be transferred to the piston pin.

Piston Pin

The piston pin joins the piston to the connecting rod. It is machined in the form of a tube from a nickel steel alloy forging, casehardened, and ground. The piston pin is sometimes called a wristpin because of the similarity between the relative motions of the piston and the articulated rod and that of the human arm. The piston pin used in modern aircraft engines is the full-floating type, so called because the pin is free to rotate in both the piston and in the connecting rod piston-pin bearing. The piston pin must be held in place to prevent the pin ends from scoring the cylinder walls. A plug of relatively soft aluminum in the pin end provides a good bearing surface against the cylinder wall.

Piston Rings

The piston rings prevent leakage of gas pressure from the combustion chamber and reduce to a minimum the seepage of oil into the combustion chamber. [Figure 1-15] The rings fit into the piston grooves but spring out to press against the cylinder walls; when properly lubricated, the rings form an effective gas seal.

Piston Ring Construction

Most piston rings are made of high-grade cast iron. [Figure 1-14] After the rings are made, they are ground to



Figure 1-15. Machined rings around a piston.

the cross-section desired. Then they are split so that they can be slipped over the outside of the piston and into the ring grooves that are machined in the piston wall. Since their purpose is to seal the clearance between the piston and the cylinder wall, they must fit the cylinder wall snugly enough to provide a gastight fit. They must exert equal pressure at all points on the cylinder wall and must make a gastight fit against the sides of the ring grooves.

Gray cast iron is most often used in making piston rings. In some engines, chrome-plated mild steel piston rings are used in the top compression ring groove because these rings can better withstand the high temperatures present at this point. Chrome rings must be used with steel cylinder walls. Never use chrome rings on chrome cylinders.

Compression Ring

The purpose of the compression rings is to prevent the escape of combustion gases past the piston during engine operation. They are placed in the ring grooves immediately below the piston head. The number of compression rings used on each piston is determined by the type of engine and its design, although most aircraft engines use two compression rings plus one or more oil control rings.

The cross-section of the ring is either rectangular or wedge shaped with a tapered face. The tapered face presents a narrow bearing edge to the cylinder wall, which helps to reduce friction and provide better sealing.

Oil Control Rings

Oil control rings are placed in the grooves immediately below the compression rings and above the piston pin bores. There may be one or more oil control rings per piston; two rings may be installed in the same groove, or they may be installed in separate grooves. Oil control rings regulate the thickness of the oil film on the cylinder wall. If too much oil enters the combustion chamber, it burns and leaves a thick coating of carbon on the combustion chamber walls, the piston head, the spark plugs, and the valve heads. This carbon can cause the valves and piston rings to stick if it enters the ring grooves or valve guides. In addition, the carbon can cause spark plug misfiring as well as detonation, pre-ignition, or excessive oil consumption. To allow the surplus oil to return to the crankcase, holes are drilled in the bottom of the oil control piston ring grooves or in the lands next to these grooves.

Oil Scrapper Ring

The oil scrapper ring usually has a beveled face and is installed in the groove at the bottom of the piston skirt. The ring is installed with the scraping edge away from the piston head or in the reverse position, depending upon cylinder position and the engine series. In the reverse position, the scrapper ring

retains the surplus oil above the ring on the upward piston stroke, and this oil is returned to the crankcase by the oil control rings on the downward stroke.

Cylinders

The portion of the engine in which the power is developed is called the cylinder. [Figure 1-16] The cylinder provides a combustion chamber where the burning and expansion of gases take place, and it houses the piston and the connecting rod. There are four major factors that need to be considered in the design and construction of the cylinder assembly. It must:

1. Be strong enough to withstand the internal pressures developed during engine operation.
2. Be constructed of a lightweight metal to keep down engine weight.
3. Have good heat-conducting properties for efficient cooling.
4. Be comparatively easy and inexpensive to manufacture, inspect, and maintain.

The cylinder head of an air cooled engine is generally made of aluminum alloy because aluminum alloy is a good conductor of heat and its light weight reduces the overall engine weight. Cylinder heads are forged or die-cast for greater strength. The inner shape of a cylinder head is generally semispherical. The semispherical shape is stronger than conventionalist



Figure 1-16. An example of an engine cylinder.

design and aids in a more rapid and thorough scavenging of the exhaust gases.

The cylinder used in the air cooled engine is the overhead valve type. [Figure 1-17] Each cylinder is an assembly of two major parts: cylinder head and cylinder barrel. At assembly, the cylinder head is expanded by heating and then screwed down on the cylinder barrel, which has been chilled. When the head cools and contracts and the barrel warms up and expands, a gastight joint results. The majority of the cylinders used are constructed in this manner using an aluminum head and a steel barrel. [Figure 1-18]

Cylinder Heads

The purpose of the cylinder head is to provide a place for combustion of the air-fuel mixture and to give the cylinder more heat conductivity for adequate cooling. The air-fuel mixture is ignited by the spark in the combustion chamber and commences burning as the piston travels toward top dead center (top of its travel) on the compression stroke. The ignited charge is rapidly expanding at this time, and pressure is increasing so that, as the piston travels through the top dead center position, it is driven downward on the power stroke.

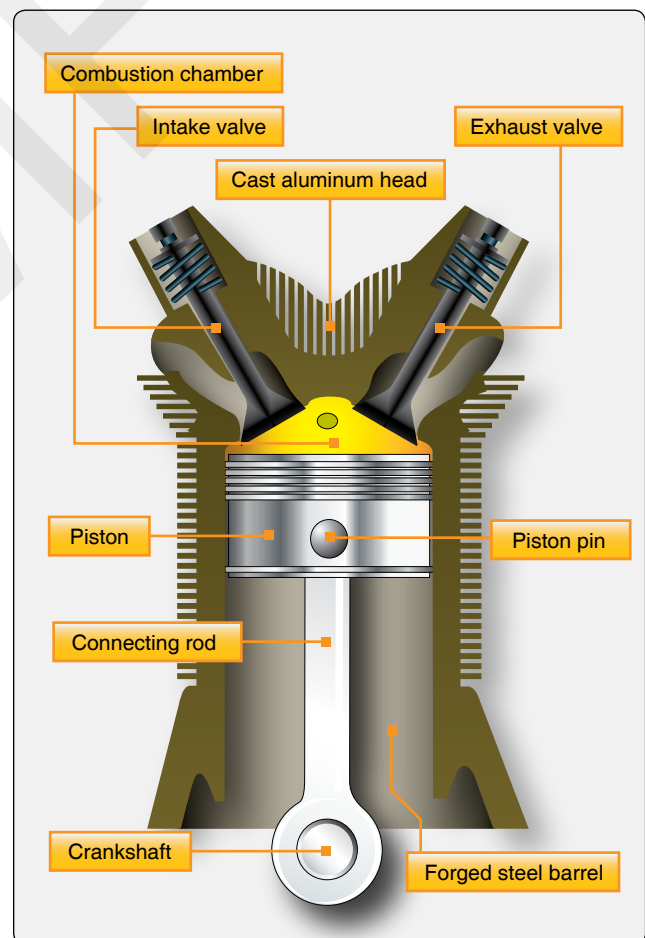

Figure 1-17. Cutaway view of the cylinder assembly.

The intake and exhaust valve ports are located in the cylinder head along with the spark plugs and the intake and exhaust valve actuating mechanisms.

After the cylinder head is cast, the spark plug bushings, valve guides, rocker arm bushings, and valve seats are installed in the cylinder head. Spark plug openings may be fitted with bronze or steel bushings that are shrunk and screwed into the openings. Stainless steel Heli-Coil spark plug inserts are used in many engines currently manufactured. Bronze or steel valve guides are usually shrunk or screwed into drilled openings in the cylinder head to provide guides for the valve stems. These are generally located at an angle to the center line of the cylinder. The valve seats are circular rings of hardened metal that protect the relatively soft metal of the cylinder head from the hammering action of the valves (as they open and close) and from the exhaust gases.

The cylinder heads of air cooled engines are subjected to extreme temperatures; it is therefore necessary to provide adequate cooling fin area and to use metals that conduct heat rapidly. Cylinder heads of air cooled engines are usually cast or forged. Aluminum alloy is used in the construction for a number of reasons. It is well adapted for casting or for the machining of deep, closely spaced fins, and it is more resistant than most metals to the corrosive attack of tetraethyl lead in gasoline. The greatest improvement in air cooling has resulted from reducing the thickness of the fins and increasing their depth. In this way, the fin area has been increased in modern engines. Cooling fins taper from 0.090" at the base to 0.060" at the tip end. Because of the difference in temperature in the various sections of the cylinder head, it is necessary to provide more cooling-fin area on some sections than on others. The exhaust valve region is the hottest part of the internal surface; therefore, more fin area is provided around the outside of the cylinder in this section.



Figure 1-18. The aluminum head and steel barrel of a cylinder.

Cylinder Barrels

The cylinder barrel in which the piston operates must be made of a high-strength material, usually steel. It must be as light as possible yet have the proper characteristics for operating under high temperatures. It must be made of a good bearing material and have high tensile strength. The cylinder barrel is made of a steel alloy forging with the inner surface hardened to resist wear of the piston and the piston rings which bear against it. This hardening is usually done by exposing the steel to ammonia or cyanide gas while the steel is very hot. The steel soaks up nitrogen from the gas, which forms iron nitrides on the exposed surface. As a result of this process, the metal is said to be nitrided. This nitriding only penetrates into the barrel surface a few thousandths of an inch. As the cylinder barrels wear due to use, they can be repaired by chroming. This is a process that plates chromium on the surface of the cylinder barrel and brings it back to new standard dimensions. Chromium-plated cylinders should use cast iron rings. Honing the cylinder walls is a process that brings it to the correct dimensions and provides crosshatch pattern for seating the piston rings during engine break-in. Some engine cylinder barrels are choked at the top, or they are smaller in diameter to allow for heat expansion and wear.

In some instances, the barrel has threads on the outside surface at one end so that it can be screwed into the cylinder head. The cooling fins are machined as an integral part of the barrel and have limits on repair and service.

Cylinder Numbering

Occasionally, it is necessary to refer to the left or right side of the engine or to a particular cylinder. Therefore, it is necessary to know the engine directions and how cylinders of an engine are numbered. The propeller shaft end of the engine is always the front end, and the accessory end is the rear end, regardless of how the engine is mounted in an aircraft. When referring to the right side or left side of an engine, always assume the view is from the rear or accessory end. As seen from this position, crankshaft rotation is referred to as either clockwise or counterclockwise.

Inline and V-type engine cylinders are usually numbered from the rear. In V-engines, the cylinder banks are known as the right bank and the left bank, as viewed from the accessory end. [Figure 1-19] The cylinder numbering of the opposed engine shown begins with the right rear as No. 1 and the left rear as No. 2. The one forward of No. 1 is No. 3; the one forward of No. 2 is No. 4, and so on. The numbering of opposed engine cylinders is by no means standard. Some manufacturers number their cylinders from the rear and others from the front of the engine. Always refer to the appropriate engine manual to determine the numbering system used by that manufacturer.

Single-row radial engine cylinders are numbered clockwise when viewed from the rear. Cylinder No. 1 is the top cylinder. In double-row engines, the same system is used. The No. 1 cylinder is the top one in the rear row. No. 2 cylinder is the first one clockwise from No. 1, but No. 2 is in the front row. No. 3 cylinder is the next one clockwise to No. 2 but is in the rear row. Thus, all odd-numbered cylinders are in the rear row, and all even-numbered cylinders are in the front row.

Firing Order

The firing order of an engine is the sequence in which the power event occurs in the different cylinders. The firing order is designed to provide for balance and to eliminate vibration to the greatest extent possible. In radial engines, the firing order must follow a special pattern since the firing impulses must follow the motion of the crank throw during its rotation. In inline engines, the firing orders may vary somewhat, yet most orders are arranged so that the firing of cylinders is evenly distributed along the crankshaft. Six-cylinder inline engines generally have a firing order of 1-5-3-6-2-4. Cylinder firing order in opposed engines can usually be listed in pairs of cylinders, as each pair fires across the center main bearing. The firing order of six-cylinder opposed engines is 1-4-5-2-3-6. The firing order of one model four-cylinder opposed engine is 1-4-2-3, but on another model, it is 1-3-2-4.

Single-Row Radial Engines

On a single-row radial engine, all the odd-numbered cylinders fire in numerical succession; then, the even numbered cylinders fire in numerical succession. On a five-cylinder radial engine, for example, the firing order is 1-3-5-2-4, and on a seven-cylinder radial engine it is 1-3-5-7-2-4-6. The firing order of a nine-cylinder radial engine is 1-3-5-7-9-2-4-6-8.

Double-Row Radial Engines

On a double-row radial engine, the firing order is somewhat complicated. The firing order is arranged with the firing impulse occurring in a cylinder in one row and then in a cylinder in the other row; therefore, two cylinders in the same row never fire in succession.

An easy method for computing the firing order of a 14-cylinder, double-row radial engine is to start with any number from 1 to 14 and add 9 or subtract 5 (these are called the firing order numbers), whichever gives an answer between 1 and 14, inclusive. For example, starting with 8, 9 cannot be added since the answer would then be more than 14; therefore, subtract 5 from 8 to get 3, add 9 to 3 to get 12, subtract 5 from 12 to get 7, subtract 5 from 7 to get 2, and so on.

The firing order numbers of an 18-cylinder, double-row radial engine are 11 and 7; that is, begin with any number from 1 to 18 and add 11 or subtract 7. For example, beginning with 1, add 11 to get 12; 11 cannot be added to 12 because the total would be more than 18, so subtract 7 to get 5, add 11 to 5 to get 16, subtract 7 from 16 to get 9, subtract 7 from 9 to get 2, add 11 to 2 to get 13, and continue this process for 18 cylinders.

Valves

The air-fuel mixture enters the cylinders through the intake valve ports, and burned gases are expelled through the exhaust valve ports. The head of each valve opens and closes these cylinder ports. The valves used in aircraft engines are the conventional poppet type. The valves are also typed by their shape and are called either mushroom or tulip because of their resemblance to the shape of these plants. *Figure 1-20* illustrates various shapes and types of these valves.

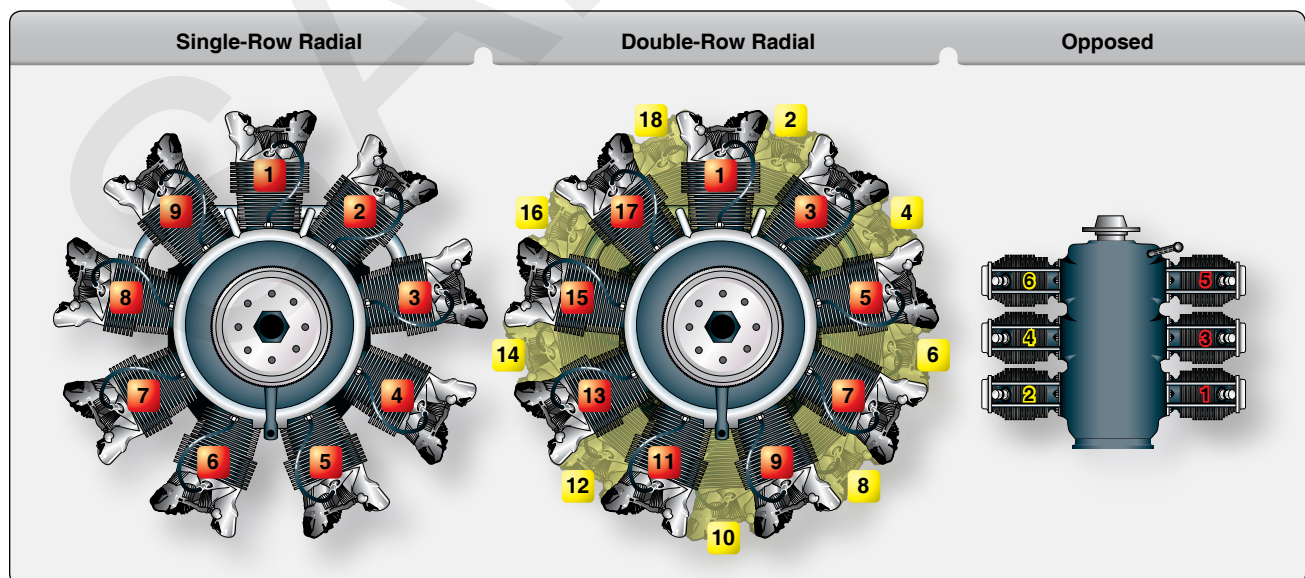

Figure 1-19. Numbering of engine cylinders.

Valve Construction

The valves in the cylinders of an aircraft engine are subjected to high temperatures, corrosion, and operating stresses; thus, the metal alloy in the valves must be able to resist all these factors. Because intake valves operate at lower temperatures than exhaust valves, they can be made of chromic-nickel steel. Exhaust valves are usually made of nichrome, silchrome, or cobalt-chromium steel because these materials are much more heat resistant.

The valve head has a ground face that forms a seal against the ground valve seat in the cylinder head when the valve is closed. The face of the valve is usually ground to an angle of either 30° or 45°. In some engines, the intake-valve face is ground to an angle of 30°, and the exhaust-valve face is ground to a 45° angle. Valve faces are often made more durable by the application of a material called stellite. About 1/16 inch of this alloy is welded to the valve face and ground to the correct angle. Stellite is resistant to high-temperature corrosion and also withstands the shock and wear associated with valve operation. Some engine manufacturers use a nichrome facing on the valves. This serves the same purpose as the stellite material.

The valve stem acts as a pilot for the valve head and rides in

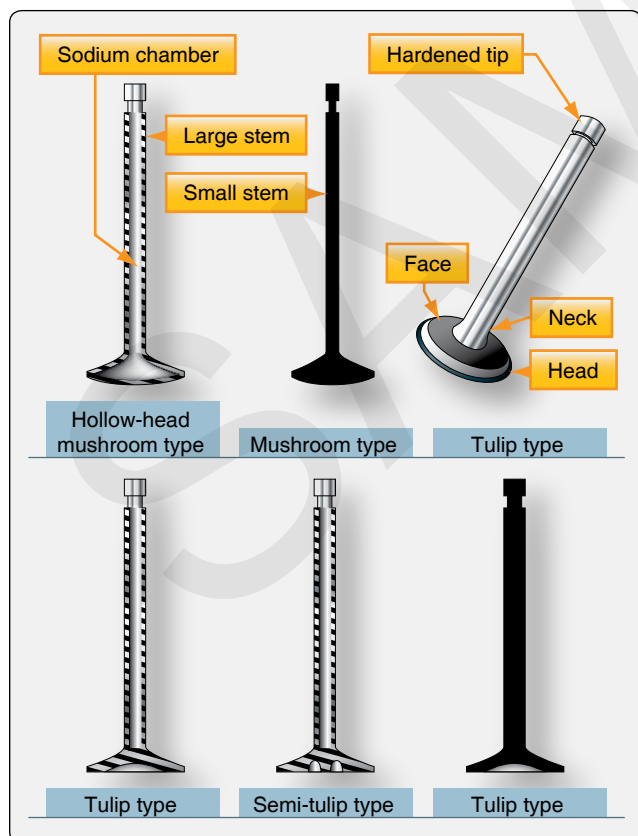

Figure 1-20. Various valve types.

the valve guide installed in the cylinder head for this purpose. [Figure 1-21] The valve stem is surface hardened to resist wear. The neck is the part that forms the junction between the head and the stem. The tip of the valve is hardened to withstand the hammering of the valve rocker arm as it opens the valve. A machined groove on the stem near the tip receives the split-ring stem keys. These stem keys form a lock ring to hold the valve spring retaining washer in place. [Figure 1-22]

Some intake and exhaust valve stems are hollow and partially filled with metallic sodium. This material is used because it is an excellent heat conductor. The sodium melts at approximately 208 °F and the reciprocating motion of the valve circulates the liquid sodium, allowing it to carry away heat from the valve head to the valve stem where it is dissipated through the valve guide to the cylinder head and the cooling fins. Thus, the operating temperature of the valve may be reduced as much as 300° to 400 °F. Under no circumstances should a sodium-filled valve be cut open



Figure 1-21. View of valve guide installed on a cylinder head.



Figure 1-22. Stem keys forming a lock ring to hold valve spring retaining washers in place.

or subjected to treatment which may cause it to rupture. Exposure of the sodium in these valves to the outside air results in fire or explosion with possible personal injury.

The most commonly used intake valves have solid stems, and the head is either flat or tulip shaped. Intake valves for low-power engines are usually flat headed. In some engines, the intake valve may be the tulip type and have a smaller stem than the exhaust valve or it may be similar to the exhaust valve but have a solid stem and head. Although these valves are similar, they are not interchangeable since the faces of the valves are constructed of different material. The intake valve usually has a flat milled on the tip to identify it.

Valve Operating Mechanism

For a reciprocating engine to operate properly, each valve must open at the proper time, stay open for the required length of time, and close at the proper time. Intake valves are opened just before the piston reaches top dead center, and exhaust valves remain open after top dead center. At a particular instant, therefore, both valves are open at the same time (end of the exhaust stroke and beginning of the intake stroke). This valve overlap permits better volumetric efficiency and lowers the cylinder operating temperature. This timing of the valves is controlled by the valve-operating mechanism and is referred to as the valve timing.

The valve lift (distance that the valve is lifted off its seat) and the valve duration (length of time the valve is held open) are both determined by the shape of the cam lobes. Typical cam lobes are illustrated in *Figure 1-23*. The portion of the lobe that gently starts the valve operating mechanism moving is called a ramp, or step. The ramp is machined on each side of

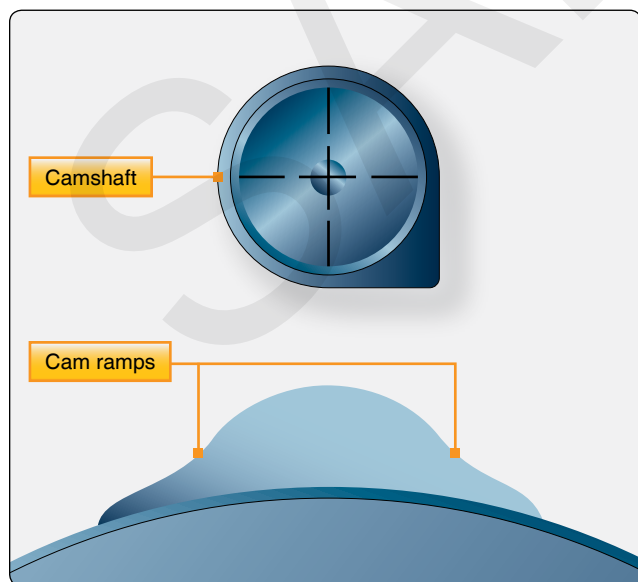

Figure 1-23. Typical cam lobes.

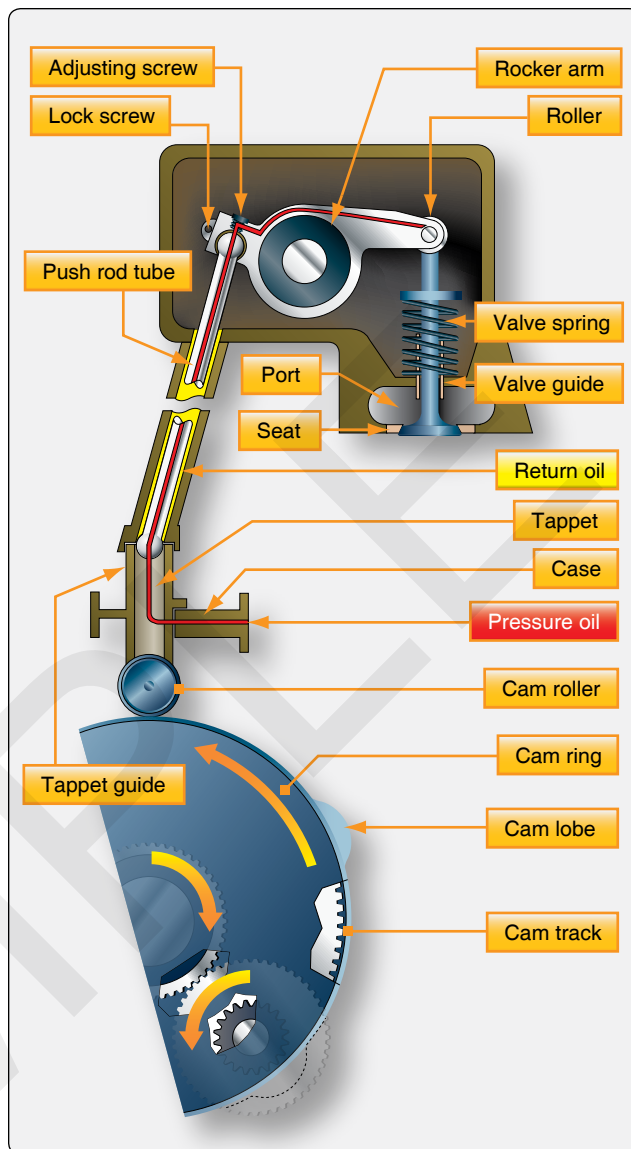

Figure 1-24. Valve-operating mechanism (radial engine).

the cam lobe to permit the rocker arm to be eased into contact with the valve tip and thus reduce the shock load which would otherwise occur. The valve operating mechanism consists of a cam ring or camshaft equipped with lobes that work against a cam roller or a cam follower. [Figures 1-24 and 1-25] The cam follower pushes a push rod and ball socket, actuating a rocker arm, which in turn opens the valve. Springs, which slip over the stem of the valves and are held in place by the valve-spring retaining washer and stem key, close each valve and push the valve mechanism in the opposite direction. [Figure 1-26]

Cam Rings

The valve mechanism of a radial engine is operated by one or two cam rings, depending upon the number of rows of cylinders. In a single-row radial engine, one ring with a double cam track is used. One track operates the intake valves, the other

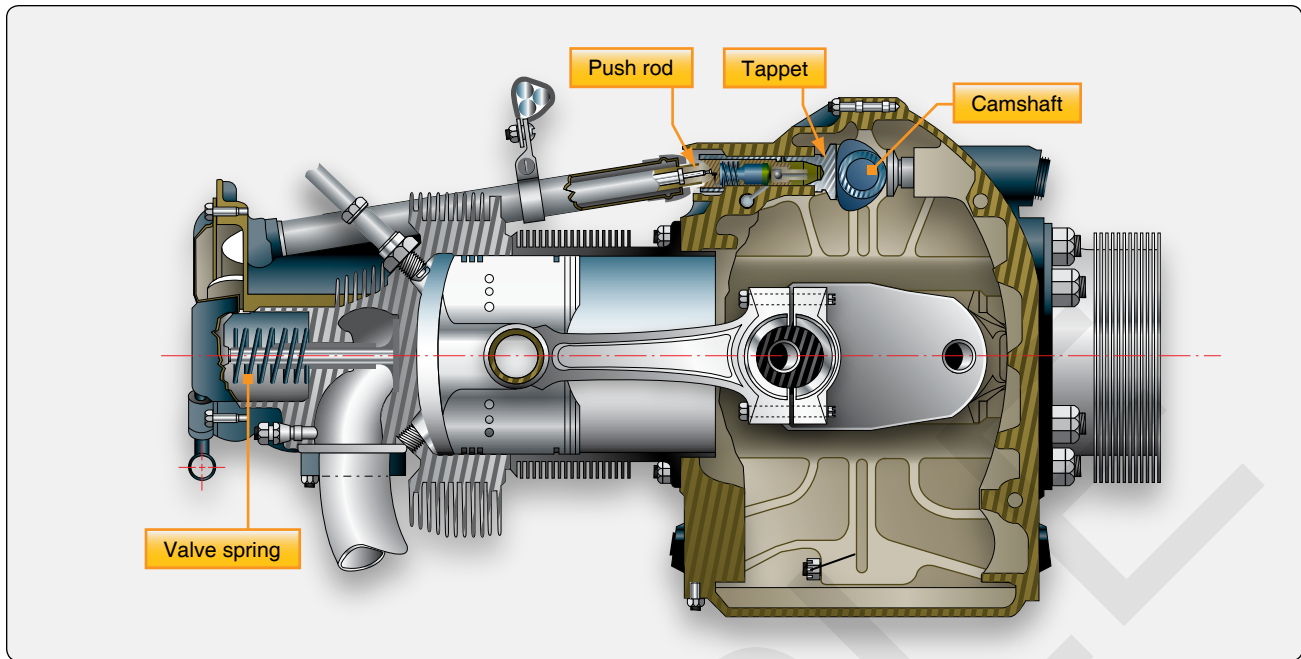

Figure 1-25. *Valve-operating mechanism (opposed engine).*

operates the exhaust valves. The cam ring is a circular piece of steel with a series of cams or lobes on the outer surface. The surface of these lobes and the space between them (on which the cam rollers ride) is known as the cam track. As the cam ring revolves, the lobes cause the cam roller to raise the tappet in the tappet guide, thereby transmitting the force through the push rod and rocker arm to open the valve. In a single-row radial engine, the cam ring is usually located between the propeller reduction gearing and the front end of the power section. In a twin-row radial engine, a second cam for the operation of the valves in the rear row is installed between the rear end of the power section and the supercharger section.

The cam ring is mounted concentrically with the crankshaft and is driven by the crankshaft at a reduced rate of speed

through the cam intermediate drive gear assembly. The cam ring has two parallel sets of lobes spaced around the outer periphery, one set (cam track) for the intake valves and the other for the exhaust valves. The cam rings used may have four or five lobes on both the intake and the exhaust tracks. The timing of the valve events is determined by the spacing of these lobes and the speed and direction at which the cam rings are driven in relation to the speed and direction of the crankshaft. The method of driving the cam varies on different makes of engines. The cam ring can be designed with teeth on either the inside or outside periphery. If the reduction gear meshes with the teeth on the outside of the ring, the cam turns in the direction of rotation of the crankshaft. If the ring is driven from the inside, the cam turns in the opposite direction from the crankshaft. [Figure 1-24]



Figure 1-26. *A typical set of valve springs used to dampen oscillations. Multiple springs are used to protect against breakage.*

A four-lobe cam may be used on either a seven-cylinder or nine-cylinder engine. [Figure 1-27] On the seven cylinder, it rotates in the same direction as the crankshaft, and on the nine cylinder, opposite the crankshaft rotation. On the nine-cylinder engine, the spacing between cylinders is 40° and the firing order is 1-3-5-7-9-2-4-6-8. This means that there is a space of 80° between firing impulses. The spacing on the four lobes of the cam ring is 90° , which is greater than the spacing between impulses. Therefore, to obtain proper relation of valve operations and firing order, it is necessary to drive the cam opposite the crankshaft rotation. Using the four-lobe cam on the seven-cylinder engine, the spacing between the firing of the cylinders is greater than the spacing of the cam lobes. Therefore, it is necessary for the cam to rotate in the same direction as the crankshaft.

5 Cylinders		7 Cylinders		9 Cylinders		Direction of Rotation
Number of Lobes	Speed	Number of Lobes	Speed	Number of Lobes	Speed	
3	1/6	4	1/8	5	1/10	with crankshaft opposite crankshaft
2	1/4	3	1/6	4	1/8	

Figure 1-27. Radial engines, cam ring table.

Camshaft

The valve mechanism of an opposed engine is operated by a camshaft. The camshaft is driven by a gear that mates with another gear attached to the crankshaft. [Figure 1-28] The camshaft always rotates at one-half the crankshaft speed. As the camshaft revolves, the lobes cause the tappet assembly to rise in the tappet guide, transmitting the force through the push rod and rocker arm to open the valve. [Figure 1-29]

Tappet Assembly

The tappet assembly consists of:

1. A cylindrical tappet, which slides in and out in a tappet guide installed in one of the crankcase sections around the cam ring;
2. A tappet roller, which follows the contour of the cam ring and lobes;
3. A tappet ball socket or push rod socket; and
4. A tappet spring.

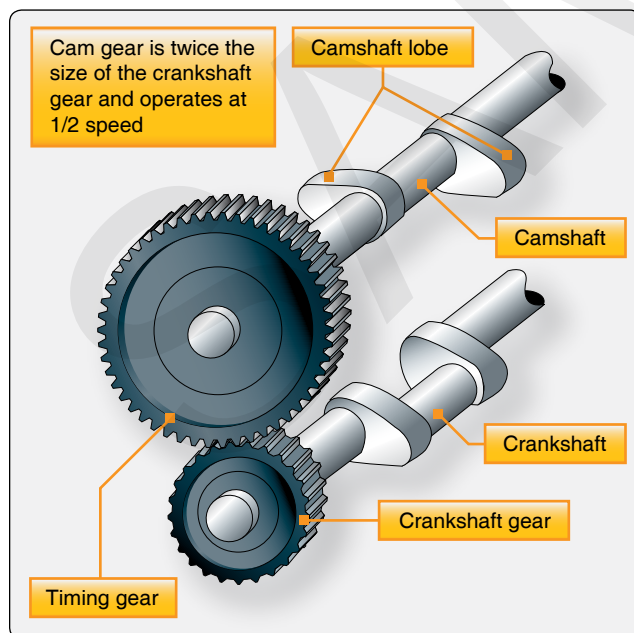

Figure 1-28. Cam drive mechanism opposed-type aircraft engine.

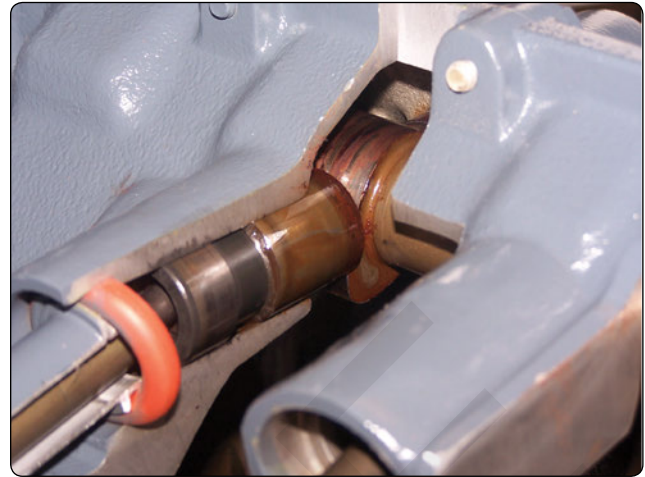

Figure 1-29. Cam load on lifter body.

The function of the tappet assembly is to convert the rotational movement of the cam lobe into reciprocating motion and to transmit this motion to the push rod, rocker arm, and then to the valve tip, opening the valve at the proper time. The purpose of the tappet spring is to take up the clearance between the rocker arm and the valve tip to reduce the shock load when the valve is opened. A hole is drilled through the tappet to allow engine oil to flow to the hollow push rods to lubricate the rocker assemblies.

Solid Lifters/Tappets

Solid lifters or cam followers generally require the valve clearance to be adjusted manually by adjusting a screw and lock nut. Valve clearance is needed to assure that the valve has enough clearance in the valve train to close completely. This adjustment or inspection was a continuous maintenance item until hydraulic lifters were used.

Hydraulic Valve Tappets/Lifters

Some aircraft engines incorporate hydraulic tappets that automatically keep the valve clearance at zero, eliminating the necessity for any valve clearance adjustment mechanism. A typical hydraulic tappet (zero-lash valve lifter) is shown in Figure 1-30.

When the engine valve is closed, the face of the tappet body (cam follower) is on the base circle or back of the cam. [Figure 1-30] The light plunger spring lifts the hydraulic plunger so that its outer end contacts the push rod socket, exerting a light pressure against it, thus eliminating any clearance in the valve linkage. As the plunger moves outward, the ball check valve moves off its seat. Oil from the supply chamber, which is directly connected with the engine lubrication system, flows in and fills the pressure chamber. As the camshaft rotates, the cam pushes the tappet body and the

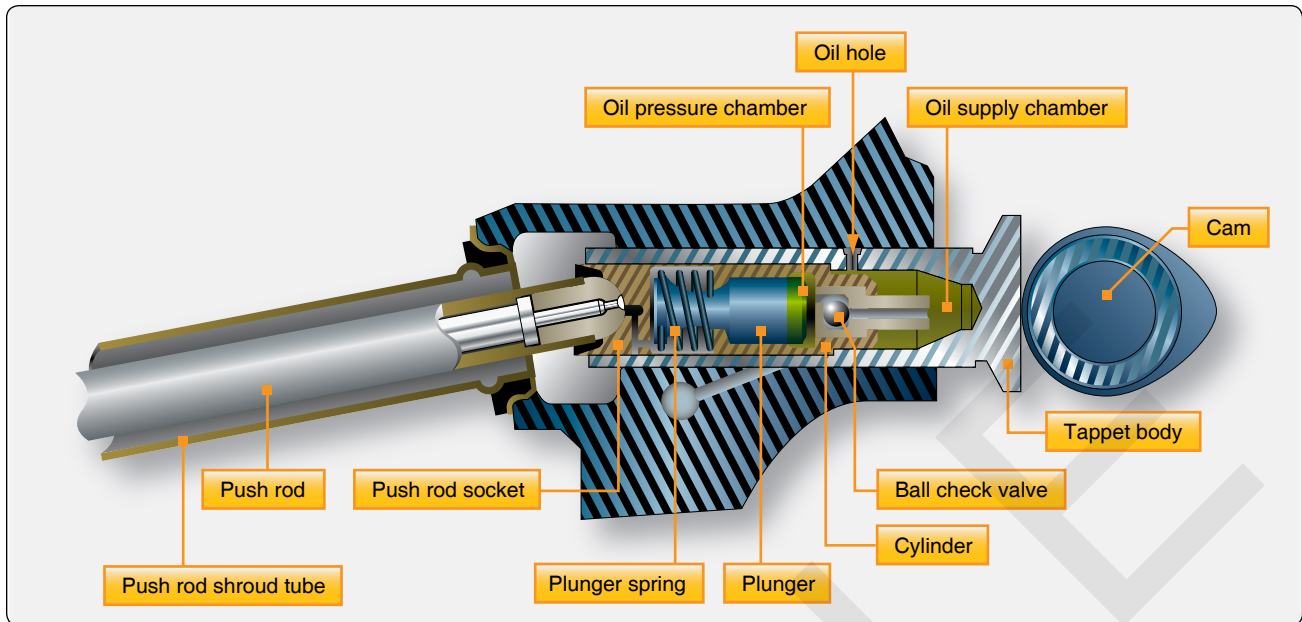

Figure 1-30. Hydraulic valve tappets.

hydraulic lifter cylinder outward. This action forces the ball check valve onto its seat; thus, the body of oil trapped in the pressure chamber acts as a cushion. During the interval when the engine valve is off its seat, a predetermined leakage occurs between plunger and cylinder bore, which compensates for any expansion or contraction in the valve train. Immediately after the engine valve closes, the amount of oil required to fill the pressure chamber flows in from the supply chamber, preparing for another cycle of operation.

Hydraulic valve lifters are normally adjusted at the time of overhaul. They are assembled dry (no lubrication), clearances checked, and adjustments are usually made by using push rods of different lengths. A minimum and maximum valve clearance is established. Any measurement between these extremes is acceptable, but approximately half way between the extremes is desired. Hydraulic valve lifters require less maintenance, are better lubricated, and operate more quietly than the screw adjustment type.

Push Rod

The push rod, tubular in form, transmits the lifting force from the valve tappet to the rocker arm. A hardened-steel ball is pressed over or into each end of the tube. One ball end fits into the socket of the rocker arm. In some instances, the balls are on the tappet and rocker arm, and the sockets are on the push rod. The tubular form is employed because of its lightness and strength. It permits the engine lubricating oil under pressure to pass through the hollow rod and the drilled ball ends to lubricate the ball ends, rocker-arm bearing, and valve-stem guide. The push rod is enclosed in a tubular housing that extends from the crankcase to the cylinder head, referred to

as push rod tubes.

Rocker Arms

The rocker arms transmit the lifting force from the cams to the valves. [Figure 1-31] Rocker arm assemblies are supported by a plain, roller, or ball bearing, or a combination of these, which serves as a pivot. Generally, one end of the arm bears against the push rod and the other bears on the valve stem. One end of the rocker arm is sometimes slotted to accommodate a steel roller. The opposite end is constructed with either a threaded split clamp and locking bolt or a tapped hole. The arm may have an adjusting screw, for adjusting the clearance between the rocker arm and the valve stem tip. The screw can be adjusted to the specified clearance to make certain that the valve closes fully.

Valve Springs

Each valve is closed by two or three helical springs. If a single spring were used, it would vibrate or surge at certain speeds. To eliminate this difficulty, two or more springs (one inside the other) are installed on each valve. Each spring vibrates at a different engine speed and rapid damping out of all spring-surge vibrations during engine operation results. Two or more springs also reduce danger of weakness and possible failure by breakage due to heat and metal fatigue. The springs are held in place by split locks installed in the recess of the valve spring upper retainer or washer, and engage a groove machined into the valve stem. The functions of the valve springs are to close the valve and to hold the valve securely on the valve seat.

Aviation Maintenance Technician Handbook— Powerplant



U.S. Department
of Transportation
**Federal Aviation
Administration**

FAA-H-8083-32B

The FAA *Aviation Maintenance Technician Handbook—Powerplant* is designed for use by instructors and applicants preparing for the FAA Knowledge Exam and Oral & Practical (O&P) Exams required to obtain an Aviation Mechanic Certificate with Airframe and/or Powerplant Ratings (also called an A&P license). Developed as one in a series of handbooks for this purpose, this is an effective text for both students and instructors and will also serve as an invaluable reference guide for current technicians who wish to improve their knowledge.

The powerplant handbook provides basic information on principles, fundamentals, and technical procedures in the subject matter areas relating to the aircraft powerplant. Subjects covered include: aircraft engines, engine fuel and fuel metering systems, induction and exhaust systems, engine ignition and electrical systems,

engine starting systems, lubrication and cooling systems, propellers, engine removal and replacement, engine fire protection systems, engine maintenance and operation, and light-sport aircraft engines.

Reflecting current technologies, equipment and procedures, the 2023 edition provides the guidance to support the FAA *Aviation Mechanic Airman Certification Standards (ACS)* and 14 CFR Part 147 Aviation Maintenance Technician Schools. Illustrated throughout with detailed, full-color drawings and photographs, the handbook also offers a comprehensive glossary and index.

Also available in this series:
General (ASA-8083-30B)
Airframe (ASA-8083-31B)

Aviation Supplies & Academics, Inc. – Since 1940
Quality and Service You Can Depend On.



Aviation Supplies & Academics, Inc.
7005 132nd Place SE
Newcastle, Washington 98059 USA
425-235-1500 | asa2fly.com

ASA-8083-32B

TRANSPORTATION USD \$46.95

ISBN 978-1-64425-350-2



9 781644 253502